

Upgrade for weight fillers



Improved slipringset



PRoCARE®

The smart way to produce
more tonnage per day

jbt.com

JBT builds weight fillers for the Dairy and Juice industry. To keep the machines up to date we introduce a continuous improvement plan. This can involve:

- ✓ Maintenance improvements
- ✓ Accuracy improvement
- ✓ Program updates

This leaflet describes an improved slip-ringset.

History

The weightfilling machine is equipped with a so called slip-ringset. This slipringset transfers air-pressure, electrical power and signals from sensors and the Penko weighing unit, from the rotating part of the filler, to the static, control cabinet and air-pressure supply.

What does it resolve?

The previous iteration of the slip-ringset had a relatively short maintenance span (< 3000 hrs), after which it had to be opened and the slip-rings had to be cleaned.

Additionally, the air pressure hose and the rotary air manifold passes through the same housing as the slip-rings. If this air pressure hose had any issues or leaks, the slip-rings get foiled much quicker than the standard maintenance interval of 3000 hrs.

Above mentioned maintenance was also difficult and could be very time consuming (8hrs)

Additionally, this new standard slip-ringset will accommodate future control upgrades as parts become obsolete, e.g. Penko weight control unit.



What is the new functionality?

In this latest and improved design, JBT incorporated all knowledge and customer feedback from the previous iteration of the slip-ringset.

This effort resulted in:

- ✓ Easier disassembly of the slip-ringset, reducing required maintenance time
- ✓ Redesign of air pressure passage: air pressure channel does not pass through the slip-ring chamber
- ✓ Contamination of the slip-rings strongly reduced.
- ✓ Making the signal exchange futureproof in light of future upgrades

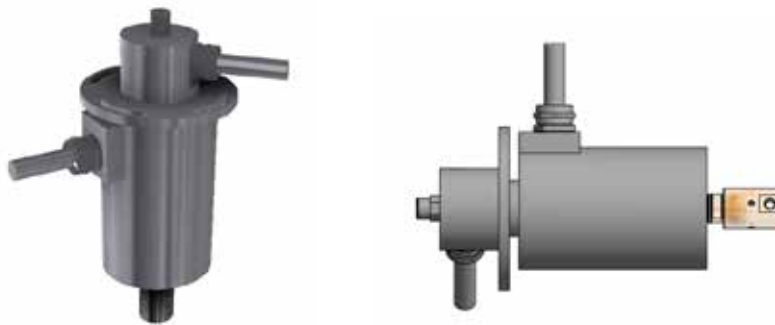

What will be modified?

The improved slipringset is mechanically a one-to-one replacement of the existing slipringset.

What's the impact?

Implementation and mounting of the improved slipringset requires 1 workday downtime.

What are the benefits?

- ✓ Reduced maintenance interval
- ✓ Reduction of maintenance duration
- ✓ Futureproof
- ✓ Maintenance free
- ✓ Higher reliability rate
- ✓ Compact design
- ✓ IP 65 with watertight connectors
- ✓ Low friction rate
- ✓ Sliding contacts gold on gold
- ✓ Air manifold outside the electrical housing
- ✓ Short delivery

Please contact your JBT customer care manager for more information or a quote.

Contact for the improved slipringset

John Bean Technologies NV - Breedstraat 3 - 9100 Sint-Niklaas | Belgium

24/7 Help Desk: +32 3 780 1444

Service Assistance: service.sn@jbt.com

Parts Assistance: parts.sn@jbt.com

Sales: sales.sn@jbt.com

COUNT ON JBT TO HELP PROTECT YOUR INVESTMENT

JBT's greatest value in PRoCARE® services comes from preventing unexpected costs through smart, purposeful, and timely maintenance based on unmatched knowledge and expertise. PRoCARE service packages are offered as a maintenance agreement in various service levels, depending on your production and cost management requirements.



JBT LIQUID FOODS

FRESH PRODUCE TECHNOLOGIES | FRESH-CUT, ROBOTICS, STEAMING | FRUIT AND VEGETABLE PROCESSING | SECONDARY PROCESSING | ASEPTIC SYSTEMS | FILLING AND CLOSING | IN-CONTAINER STERILIZING | TRAY SEALING | HIGH-PRESSURE PROCESSING | POWDER PROCESSING | TUNA PROCESSING

OUR BRANDS



Europe

JBT Food & Dairy Systems
Deccaweg 32
1042 AD Amsterdam - The Netherlands
Phone: +31 20 634 8911
Fax: +31 20 636 9754
info.ams@jbt.com

JBT Food & Dairy Systems SARL
La Frégate - Bâtiment B
1901 Avenue Jacques Cartier
44800 Saint Herblain
France
Phone: +33 02 3762 5700

John Bean Technologies NV
Breedstraat 3
9100 Sint-Niklaas
Belgium
24/7 Help Desk: +32 3 780 1444
Service Assistance: service.sn@jbt.com
Parts Assistance: parts.sn@jbt.com

John Bean Technologies SpA
Via Mantova 63/A
43122 Parma
Italy
Phone: +39 0521 908 411
service.parma@jbt.com

John Bean Technologies Foodtech Spain S.L.
Autovía A-2, Km 34,400 - Edificio 1 y 3
28805 Alcala de Henares
Madrid, Spain
Phone: +34 91 304 0045
Fax: +34 91 327 5003

John Bean Technologies Sp. z o.o.
ul. Przy Bazantarni 11
02-793 Warszawa, Poland
Phone: +48 22 894 9025
Fax: +48 22 894 9041

JBT Corporation
Petrovka str. 27
Moscow, Russia 107031
Phone: +7 495 221 87 13
Phone: +7 495 221 87 14 (2 lines)

North America

John Bean Technologies Corporation
400 Fairway Avenue
Lakeland, FL 33801
USA
Phone: +1 863 683 5411
Fax: +1 863 680 3672

South America

John Bean Technologies Máq.
e Equip. Ind. Ltda.
Av. Eng Camilo Dinucci 4605
14808-900 Araraquara, São Paulo
Brazil
Phone: +55 16 3301 2000
Fax: +55 16 3301 2144

Latin America

JBT de México S de RL de CV
Camino Real a San Andrés Cholula No. 2612
Col. San Bernardino Tlaxcalancingo
72820 San Andrés Cholula, Puebla
México
Phone: +52 222 329 4902
Fax: +52 222 329 4903

Asia Pacific

John Bean Technologies (Thailand) Ltd.
No. 159/26 Serm-Mit Tower 16th Floor
Room no. 1602-3 Sukhumvit 21 Road
Klongtoey Nua Sub-district, Wattana District
Bangkok 10110 Thailand
Phone: +66 2 257 4000
Fax: +66 2 261 4099

John Bean Technologies (Shanghai) Co., Ltd.
Room 1908, Hongwell International Plaza,
1600 West Zhongshan Road,
Xuhui District, Shanghai 200235,
PRC
Phone: +86 21 3339 1588
Fax: +86 21 3339 1599

South Africa

John Bean Technologies (Pty) Ltd.
Koper Street
Brackenfell
Cape Town, South Africa 7560
Phone: +27 21 982 1130
Fax: +27 21 982 1136

We're with you, right down the line.™

hello@jbt.com | jbt.com

