

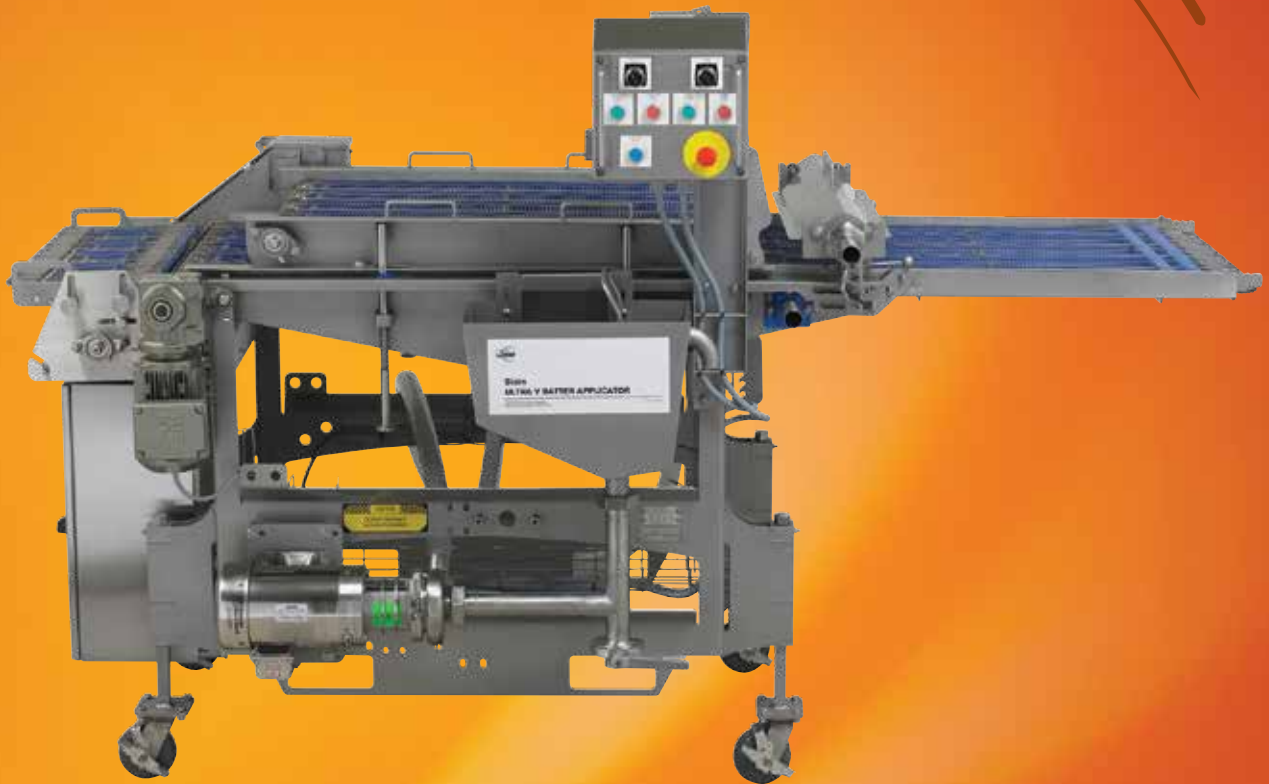

Stein Ultra V™ Batter Applicator

Specifications



Ultra V™ Batter Applicator Specifications



Benefits

- Available in top submerger and/or overflow configuration
- Handles standard batters as well as light tempura
- Good removal of excess batter
- Easy to set up and operate
- Settings repeatability
- Quick product changeover
- Available with electric or hydraulic drives
- Top submerger single-point adjustment and parallel profile
- Threaded caster mechanism, for easy, accurate height adjustment
- Infeed adjustment
- Level pan Installation without breaking main belt
- Machine mounted Electric Blower option
- Stainless steel pumps and piping
- Easy to clean, with minimal parts removal
- Flexible

Ultra V™ Batter Applicator Specifications

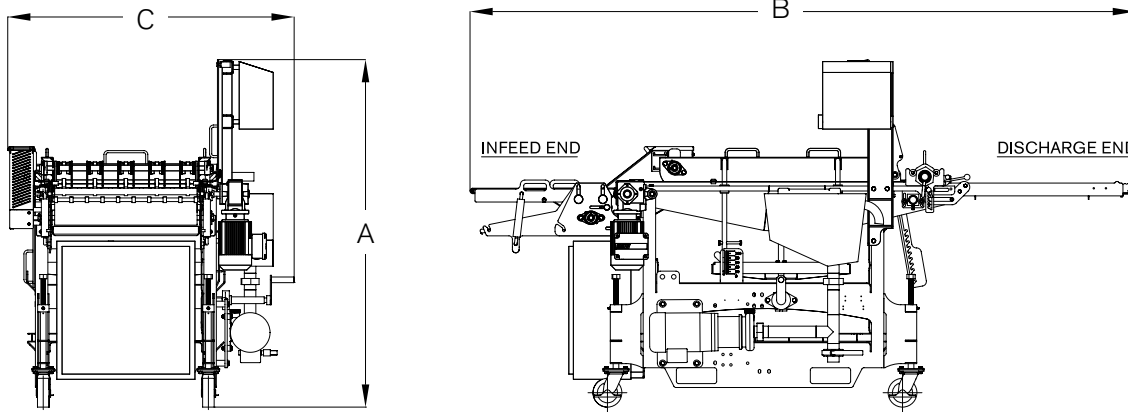

Model	SUV BA 600		SUV BA 1000		
	Inch (in)	Metric (mm)	Inch (in)	Metric (mm)	
A. Height	60.8 ^{+6.5} ₋₀	1544 ⁺¹⁶⁵ ₋₀	60.8 ^{+6.5} ₋₀	1544 ⁺¹⁶⁵ ₋₀	
B. Length	115.6	2936	119.5	3036	
C. Width	Electric	49.5	65	1651.9	
	Hydraulic	57.3	1455.6	72.9	1851
Usable Belt Width	23.6	600	39.4	1000	
Hydraulic motor requirement at 6210 kPa or 900 psi minimum hydraulic pressure* Maximum Allowable Hydraulic Pressure 6900 kPa or 1000psi					
Total Hydraulic Consumption**	l/min	76		76	
(operating flow may be lower)	GPM	20		20	
Electric Drive at 460V/3/60Hz					
Full Load Current**	A	14 A @ 460 V		19 A @ 460 V	
Electric Drive at 380V/3/50Hz					
Full Load Current**	A	17 A @ 380 V		23 A @ 380 V	
Batter Capacity					
	min/max	6-11 gal	22.7-41.6 liters	11-30.5 gal	41.6-115.5 liters
Blower Tube Air Requirement (maximum per tube)					
(30-35" WC/7.5-8.7 kPa)	m ³ /hr		42		59
	cfm		25		35
Casters (center-to-center distance)					
	Standard	28.7 in	728.3 mm	43.5 in	1105 mm
	V-Groove	27.5 in	698.5 mm	43.5 in	1105 mm
Batter Applicator Weight					
	Main Body Net	900 lb	408 kg	1100 lb	499 kg
Noise Level					
		70 dbA		70 dbA	

* Suggested settings at product belt speed of 18.5 m/min (60 fpm)

**Computed with standard items only

Specifications subject to change without notice. Please corroborate with Stein sales support in your region



We are your single source for profitable processing solutions

JBT can provide you with portioners, freezers, and everything in between – including process control, food product development assistance, operator training and a full range of customer support alternatives.

Our Food Technology Centers have served leading processors in the development of many of the world's most popular food brands. Learn how to increase your processing potential by contacting your JBT Representative or by visiting our website.

We're with you right down the line.™

www.jbtfoodtech.com



www.jbtfoodtech.com

North America

JBT
1622 First Street
Sandusky, OH 44870
USA
Phone +1 419 626 0304
Fax +1 419 626 9560
process-solutions@jbt.com

Asia

John Bean Technologies (Thailand) Ltd.
159/26 Serm-Mit Tower, Room no. 1602-3
Sukhumvit 21 Road, Klongtoey Nua Sub-district
Wattana District, Bangkok 10110 Thailand
Phone: + 66 2257 4000
Fax: + 66 2261 4099
infoasia-jbtfoodtech@jbt.com

Europe

JBT
Rusthallsgatan 21, Box 913
SE-251 09 Helsingborg
SWEDEN
Phone +46 42 490 4000
Fax +46 42 490 4040
info@jbtfoodtech.com

Latin America

John Bean Technologies
Máq. Equip. Ind. Ltda.
Av Eng Luis Carlos Berrini, 1461
9th Floor – Brooklin
04571-903 Sao Paulo BRAZIL
Phone + 55 11 3055 1010
Fax +55 11 3055 1030
latinamerica.info@jbt.com