



**STRONGER  
TOGETHER**

**PRIME  
EQUIPMENT GROUP**  
*Simple Solutions for Poultry Processing*

## PRIME COUNTER-ROTATING PICKER WITH HOCK-PICKING DRUMS

Model No. RF-6

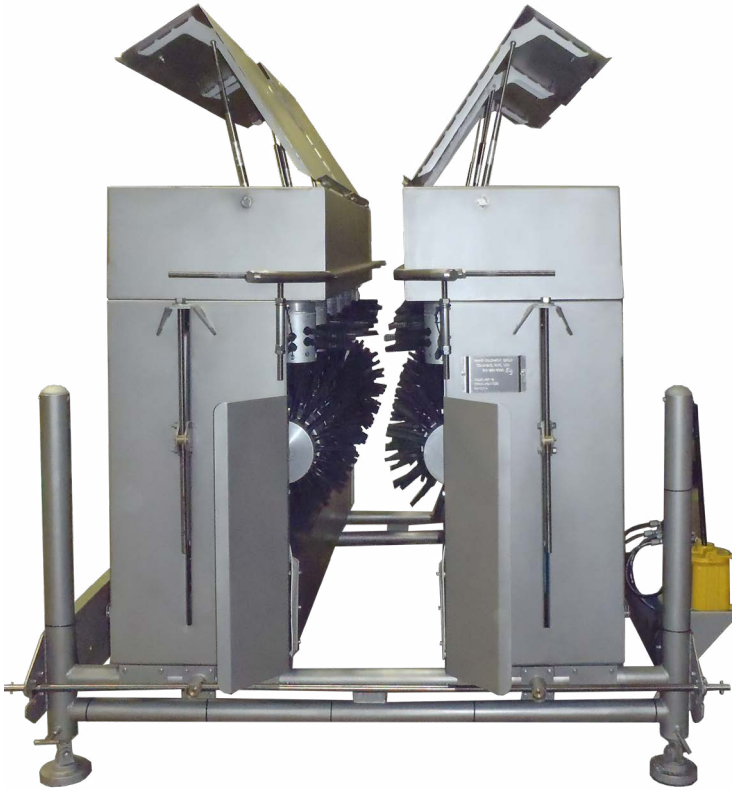

The Prime RF-6 Counter-Rotating Picker utilizes the most effective and versatile defeathering method available. The first opposing drums pick downward; the next pick upward, for maximum picking success. Additional banks of picking drums focus on hocks at the same time. This innovative method allows lower scalding temperatures. Also, the skin remains more firmly attached to assure a product of higher grade and yield, with better appearance and value.

See Prime in action: View  
[www.YouTube.com/user/PrimeEquip](http://www.YouTube.com/user/PrimeEquip)

Viewing online?  
Click here

MOST VERSATILE AND EFFICIENT SOLUTION  
FOR DEFEATHERING

ALTERNATING ROTATION ASSURES  
LESS-TIGHT PICKING

IMPROVED PICKING ALLOWS LOWER  
SCALDING TEMPERATURES

HOCK-PICKING DRUMS UP EFFICIENCY

### PRIME ROI:

PROVEN DESIGN AND DURABILITY REDUCE MAINTENANCE COSTS

KEEPS SKIN FIRMLY ATTACHED FOR HIGHER GRADE AND YIELD

MORE EFFICIENT PICKING ALLOWS LOWER SCALD WATER  
TEMPERATURES TO LOWER HEATING COSTS



2001 Courtright Road  
Columbus, OH 43232 USA



Please call  
+1 (614) 253-8590



Send us an email  
[Sales@PrimeEquipmentGroup.com](mailto:Sales@PrimeEquipmentGroup.com)



More info  
[PrimeEquipmentGroup.com](http://PrimeEquipmentGroup.com)



**STRONGER  
TOGETHER**

**PRIME  
EQUIPMENT GROUP**  
*Simple Solutions for Poultry Processing*

# PRIME COUNTER-ROTATING PICKER WITH HOCK-PICKING DRUMS

Model No. RF-6

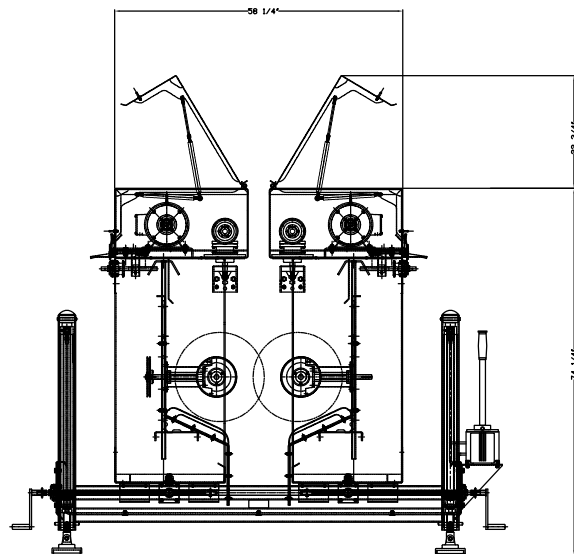
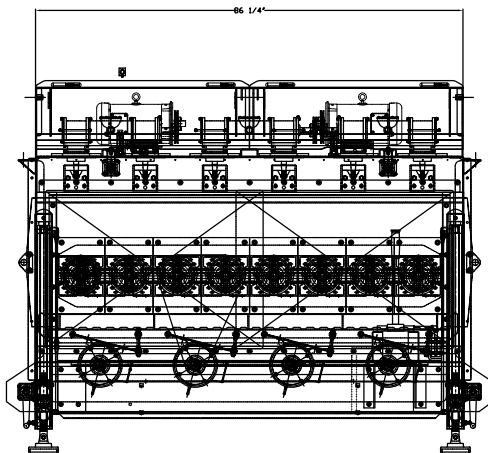
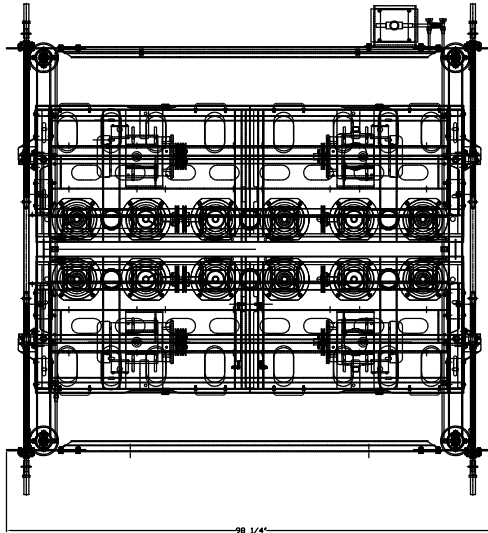

## TECHNICAL SPECIFICATIONS

Electrical Requirements:	230-460V, 60 Hz, 3 ph
Motor Specs:	(12) - 3 HP Motors
Water Requirements:	(2) - 1" Pipelines
Net Weight:	4800 lbs.
Production Rates:	Variable with line speed

NOTE: Specifications are accurate at time of publication



2001 Courtright Road  
Columbus, OH 43232 USA



Please call  
+1 (614) 253-8590



Send us an email  
[Sales@PrimeEquipmentGroup.com](mailto:Sales@PrimeEquipmentGroup.com)



More info  
[PrimeEquipmentGroup.com](http://PrimeEquipmentGroup.com)