

C.A.T.

Automated Chiller
Clean-in-Place (CIP)
Technology

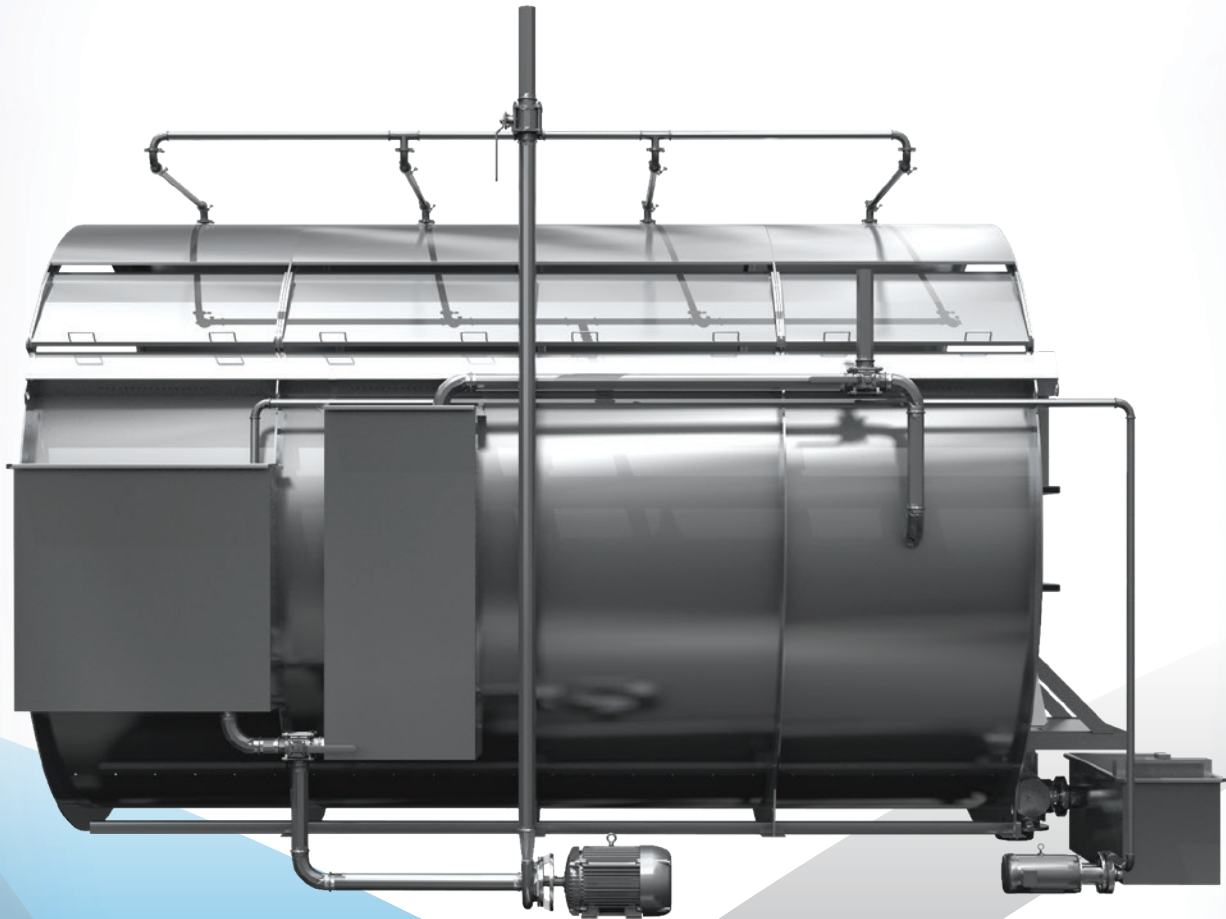

Dramatically reduce your chiller sanitation costs with JBT's innovative, automated, Clean-in-Place Technology

A safer, more consistent and effective method of chiller sanitation

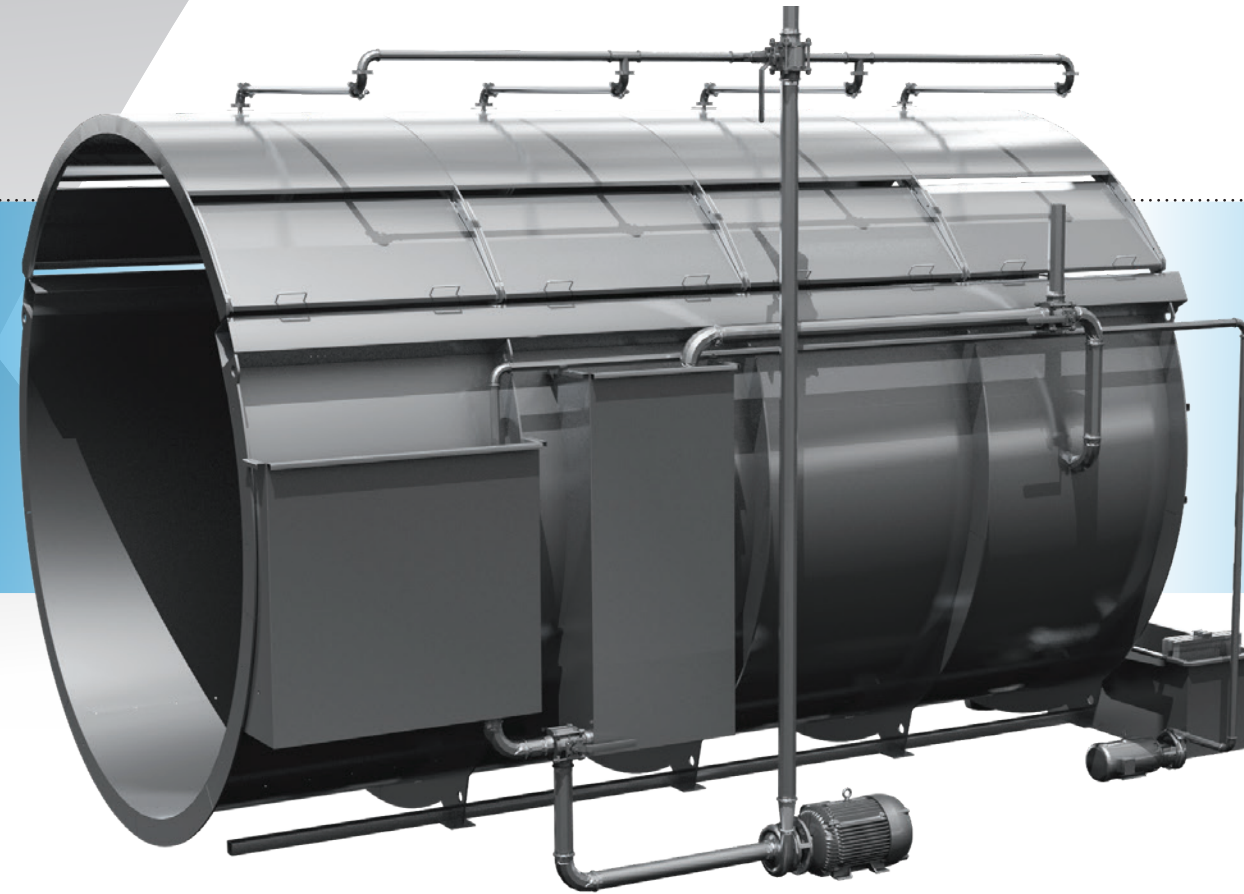

CAT-Sprinklers

Patent-pending technology practically eliminates manual cleaning labor

Cleaning chillers is a time-consuming task that often must be done every night. This can take an average of four employees as long as several hours. Now you can automate this task with JBT Clean-in-Place (CIP) Technology, significantly reducing your cost to clean.

JBT offers a wide range of sanitary, industrial tanks and CIP solutions—from design and fabrication to installation and startup.

Cut Your Cost to Clean

- Eliminate manual cleaning of chillers
- Drastically reduce your expenditures in time and personnel for cleaning

Improve Operational Hygiene

- Automated, reproducible cleaning process eliminates the inconsistencies of manual cleaning
- Enhanced plant hygiene helps ensure the quality, cleanliness and consistency of your products

Create a Safer Working Environment

- Eliminate slip-and-falls and other accidents from manually cleaning equipment

Reduce Pollution

- Water, cleaning chemicals and boiler condensate are all recycled with JBT CIP technology, helping you deliver a greener, more sustainable operation
- Production costs are reduced by reusing and recycling your cleaning liquids

Choose from a Range of Options

- JBT engineers can customize a system to meet your exact specifications, carefully selecting every component of your stainless steel system with special attention to meeting specific application needs
- We can design virtually any kind of system you need, from single-pass or single-use systems to multi-tank reuse systems
- Systems are tested in our state-of-the-art Factory Acceptance Testing (FAT) Center
- You can use your existing PLCs, self-supporting control systems or manual operations for process control
- Design criteria is based on current 3-A, USDA, cGMP, ASME (U&R), BPE, FDA and API standards

Exceptional Customer Service

Every JBT CIP system is available with our ProCARE® Promise: JBT equipment is backed by industry-leading customer care solutions and experienced technicians to help maximize your uptime, keep your lines running smoothly, and improve efficiency throughout your operation.

JBT Clean-in-Place (CIP) Specifications

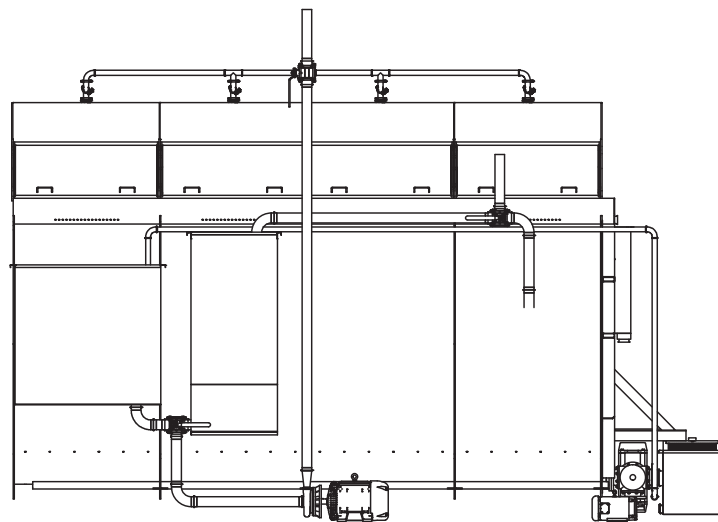
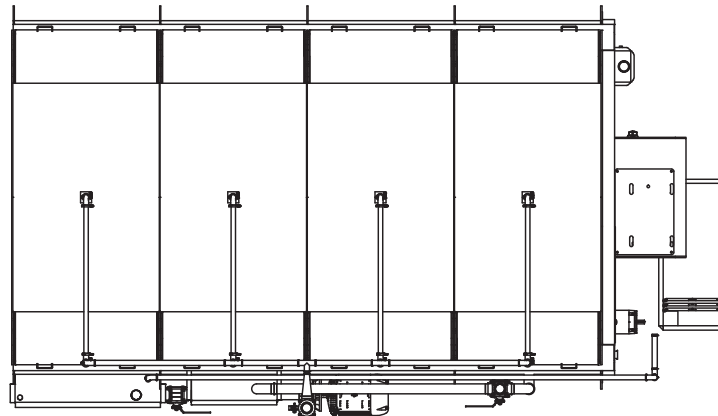

JBT PROTEIN PROCESSING

SECONDARY

BRINE PREPARATION | HOMOGENIZATION | INJECTION
INJECTION & RETURN MILLING | MACERATION | MASSAGING |
TENDERIZATION | X-RAY TECHNOLOGY | AUTOMATED TRAY LOADING

FURTHER

WEIGHING | PORTIONING/TRIMMING | COATING | FRYING & FILTRATION | PROOFING
COOKING | COOLING | CHILLING | FREEZING | REFRIGERATION | CLIPPING & PACKAGING
SOLUTIONS | X-RAY TECHNOLOGY | HIGH-PRESSURE PROCESSING (HPP)



North America

JBT
1622 First Street
Sandusky, OH 44870
USA
Phone +1 419 626 0304
Fax +1 419 626 9560
process-solutions@jbt.com

Australia

John Bean Technologies Australia Limited
Unit 1, 40 Rivergate Place
Murarrie QLD 4172
Australia
Phone: 07 3896 6100
Fax: 07 3393 9299
info.au@jbt.com
info.nz@jbt.com

Europe

JBT
Rusthallskatan 21, Box 913
SE-251 09 Helsingborg
SWEDEN
Phone +46 42 490 4000
Fax +46 42 490 4040
info-europe@jbt.com

Latin America

JBT
Máq. Equip. Ind. Ltda.
Av. Eng. Camilo Dinucci 4605
14808-900 Araraquara
São Paulo
Brazil
Phone +55 16 3301 2000
latinamerica.info@jbt.com

Asia

John Bean Technologies (Thailand) Ltd.
159/26 Serm-Mit Tower, Room No. 1602-3
Sukhumvit 21 Road
Klongtoey Nua Sub-district, Wattana
District
Bangkok 10110 Thailand
Phone: + 66 2 257 4000
Fax: + 66 2 261 4099
infoasia-jbtfoodtech@jbt.com



We're with you, right down the line.™

jbt.com