



LID CLIPPING

GT1-Lid

Fully automatic, in-line, lid placing de-nesting and tamping system designed to cut labour costs.

This is the first of our **GT1id** machine range. The **GT1id** range is based on the knowledge and experience gathered from our world-renowned GT tray-sealing machine series and the key principles found within. Some of these key principles include an integral space-saving design, an impressive 5-minute tool change time, our **ProMotion** pause-free tray spacing and our **Eseal**® 'all-electric' seal actuator.

The **GT1-Lid** system is designed to accept trays from any conveyors, clip lids onto film-sealed trays and take trays directly from a filling conveyor when no film lid is required. Through using the aforementioned features to avoid any loading errors, the **GT1-Lid** system can be fully integrated with any other in-line equipment including upstream tray-sealing machines.

Packaging Materials

Trays and Lidding

- C-PET
- A-PET
- R-PET
- Polypropylene
- Smooth Wall Foil

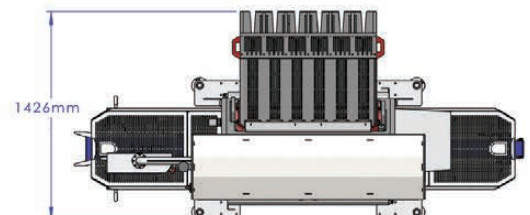
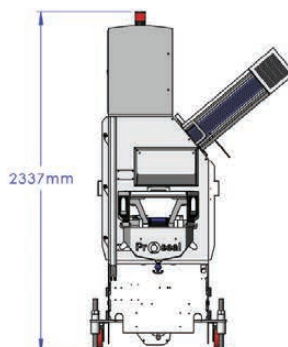
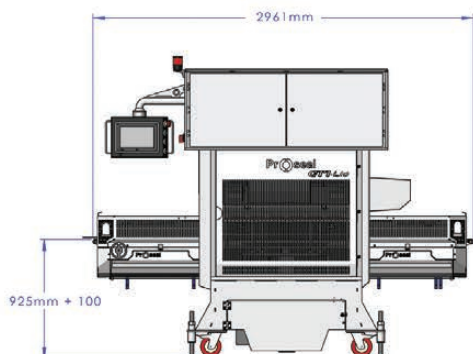

Standard design features and benefits

- Five minute tool changeover
- Low maintenance design including linear bearings
- Simple and accurate lid denesting magazine, designed to be easily and safely loaded by hand
- Maintenance-friendly sub assembly construction
- Machine can operate as a bypass conveyer when tray lidding is not required
- All 7 of the machine's axes are servo driven for complete control
- High accuracy tool alignment system provides a constantly accurate lid pick and place relationship
- Simple design and operation
- Low lid warning /error
- Tray measuring system protects against misaligned or misorientated trays
- Self-centring tray guides
- Food industry approved hygienic construction and wash-down protection
- Full Category 3 guarding
- User-friendly, menu-driven control panel with step-by-step prompts, error and status displays, and useful batch pack counter
- Recipe handling of machine settings
- Self diagnostic system
- Pendant mounted, colour touchscreen HMI control for full double-sided operation
- Recipe-driven auto machine set-up for tool change
- On-screen data capture and trends with wireless connection option
- Integration of peripheral equipment, such as: infeed and outfeed conveyors, checkweighers, metal detectors and printers
- **QRconveyors** with quick release belts for easy hygiene and maintenance
- **Eseal®** - high-performance, high-precision, high-force, energy-efficient, electric seal system that boasts a massive increase in seal force
- **Promotion** - a high accuracy continuous motion tray infeed system, which increases production speed whilst reducing machine duty

Options available

- **eWON** - a machine connection system to deliver real time data and error condition support, remote setup, and software upgrades, using a customer's existing IT network
- **ProVision** - OEE data capture system & downtime analyser
- **Protect** - a contactless machine login and audit trail system
- Sale, Lease Purchase and Rental options available

GT1-Lid Lidding capacity

No. of trays	Length	Width
Two	300mm	427mm
Three	300mm	275mm
Four	300mm	200mm
Five	300mm	154mm
Six	300mm	124mm
Seven	300mm	103mm

GT1-Lid Specifications

Height	2191mm
Standard Length	2765mm
Width	975mm
Weight	1100kg
Electrical Supply	400V 3 phase + neutral (fused at 16A)
Transformer Variations	208V 3 phase (fused at 30A) 480V 3 phase (fused at 20A) 600V 3 phase (fused at 15A)

Metric		Imperial	
Pressure	Flow	Pressure	Flow
6 Bar	142L/Min	87psi	5CFM

Transformers are available to accommodate the electrical supplier in different countries.

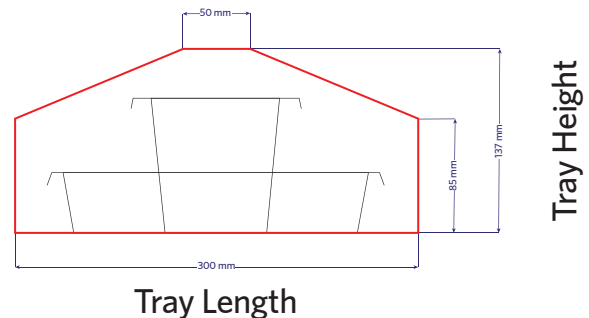

Due to the tapered swing of the turnover on our GT-Lid machines, there is a direct correlation between the tray height and tray length; thus, the more narrow the tray is the taller it can be.

For example, with a 300mm long tray the height may not exceed 85mm, however, with a 50mm tray the height can reach up to 137mm.



SNACK FOOD | A-PET



READY MEALS | THERMOFORMED POLYPROP



READY MEAL | INJECTION MOULDED POLYPROP



READY MEALS | THERMOFORMED POLYPROP



SNACK FOOD | A-PET

for more information **UK** +44 (0) 1625 856 600 **America** +1 804 447 9038 **Australia** +61 (0) 3 9397 0955

www.proseal.com