



Citrus Peel Oil Recovery Systems

Operations Manual



Copyright © John Bean Technologies Corporation 2018
JBT Corporation 400 Fairway Avenue Lakeland, FL 33801

All rights reserved

March 2018



Table of Contents

SECTION	PAGE
1. Introduction.....	4
Manual purpose	4
Peel oil source.....	4
Oil characteristics	5
Recovery methods	5
2. Terminology.....	6
3. Safety Rules	9
4. System Description.....	12
Extraction.....	12
Frit separation	12
Centrifuge system	15
De-waxing / winterizing	15
Storage	15
5. Water.....	16
Source	16
Recycling.....	16
Conditioning	17
Volumes.....	18
6. Centrifuges.....	19
Safety Alert.....	19
Operating principle and design.....	19
System configuration	24
7. System Operation.....	31
Startup responsibilities.....	25
Visual inspection	25
Startup Checklist.....	25
Initial operations	25
Startup adjustments.....	26
Sand separation.....	26
Operational adjustment.....	26
Operating Checklist	27
8. Cleaning	28
Safety alert.....	28
Frequency	28
Cleaning solutions and temperatures	28
Clean-up procedures	29



9. Equipment disassembly	30
Safety alert	30
Shutdown preparations - Short-term.....	30
Shutdown preparations - Long-term.....	30
10. Operational Logs and Report Examples.....	31
Summary of Plant Performance.....	32
11. Efficiency Calculations	33
Peel Oil Content – Florida Citrus	34
12. Quality Control and Laboratory Procedures.....	35
Typical Daily Quality Control Worksheet.....	37
Oil Analysis of Fruit and Byproducts Procedures	38
1. Whole Fruit Available Oil	38
2. Recoverable Oil in Oil Recovery System and Juice.....	43
3. Oil-Rich Emulsion Spin Test.....	49
4. Total Solids in Oil Emulsion	50
5. Recoverable Oil (Scott Method).....	51
6. Orange Cold-Pressed Oil Testing.....	54
7. Grapefruit Cold-Pressed Oil Testing.....	55
13. Troubleshooting Guidelines	56
14. Maintenance Guidelines	58
Centrifuge inspection.....	58

1. Introduction

Manual purpose

This manual has been prepared as guide to the operation of the JBT Citrus Peel Oil Recovery System. This manual is not intended to be a complete explanation on the composition and uses of peel oil. Although oil recovery systems may differ in design or layout because of the continuing improvement policy of JBT, the system can operate at its peak efficiency capability by following the guidance offered in this manual.

Peel oil source

The outer peel, called the flavedo, of citrus fruit has a large number of very small glands, each containing a minute drop of essential oil (**Figure 1**). The efficient recovery of this essential oil, commonly called peel oil, is an important function in well-managed citrus processing plants. Peel oil is a valuable product that is further refined into many different chemical compounds. These chemical compounds are considered highly desirable by many because they are derived from an organic source rather than from a petroleum source. Uses for these naturally occurring organic compounds range from flavoring foods and beverages to improving the effectiveness of biodegradable cleaning solutions.

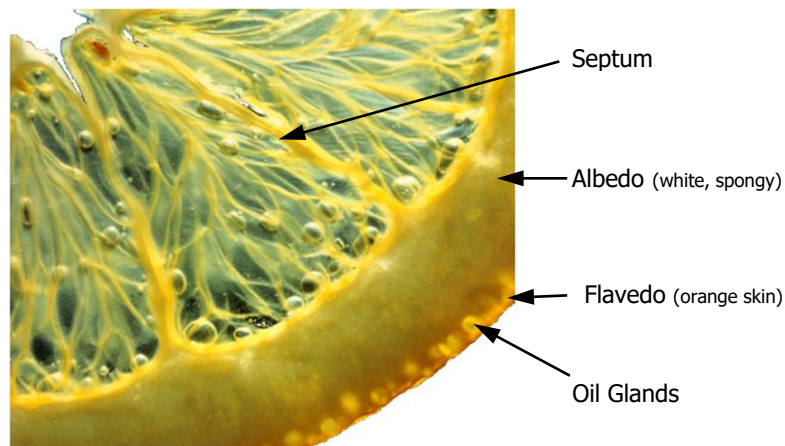

Figure 1 – Orange Structure



Oil characteristics

Citrus peel oils have natural antioxidant properties that have proven useful in protecting the flavor and other quality characteristics of citrus juices and concentrates. Oils generally have the characteristic odor and flavor of the fruit from which they are obtained. The major chemical classes present in the peel oil are terpenes and the hydrocarbon.

The appearance of the oil varies from water clear to deep opaque amber from orange varieties and from clear to deep opaque greenish/black for grapefruit oils. Lemon oil can range from a deep emerald green to yellow, depending on fruit variety and maturity. Usually, only heat-distilled oils are clear in color, while cold-pressed oils take on a characteristic color of the fruit from which they are produced. A cloudy appearance can be the result of bacterial action or from wax precipitation (most common cause).

For maximum quality protection, citrus oil should not come into contact with metals other than stainless steel. Iron and copper may act as a degradation catalyst, lowering the quality of the oil. Commercial flavor samples should be packaged only in brown glass bottles sealed with natural cork stoppers (preferably) to protect delicate flavor components.

Recovery methods

Peel oil is recovered during the JBT juice extraction cycle. This process is described later in this manual. Because no heat is used during the oil recovery and refinement process, the oil is called “cold-pressed.” Other methods are also used in most citrus plants to recovery oil, but JBT's cold-pressed method results in oil of the highest quality at greatest yields.



2. Terminology

There are a few technical terms that need to be known in order to understand the rest of this manual. By using these common terms when requesting assistance from JBT, it will improve the understanding of the problems you may be experiencing.

Three-phase Separator (De-sludger)

The first stage centrifuge that is used to remove most of the water and the peel solids from the oil-bearing emulsion.

Polisher

The second stage centrifuge that removes the remaining traces of water and peel solids from the oil-rich emulsion produced by the first stage desludging centrifuge.

Emulsion

A mixture of oil and water where the oil is very finely dispersed, as micro-droplets in the water.

Frit

The small particles of peel that are produced when the peel is removed from the rest of the fruit in the extraction cycle.

Frit Removal Equipment

The equipment that separates the oil-water emulsion and the frit. It may be a paddle finisher, a screw finisher, a vibratory shaker screen, or a static screen device, depending on individual system design. It may also contain more than one stage.

Recycle water

The water that is removed by the first stage centrifuge that, after filtration, is recycled to collect oil at the extractor.

Sludge

The wetted solid material (pulp and peel) that is removed by the centrifuge from the emulsion and discharged during each cycle of a centrifuge.

Shoot

The rapid opening and closing of the centrifuge bowl when discharging accumulated sludge.

Oil-rich Emulsion or “Cream”

The concentrated oil and water that remains after the sludge and the most of the water is removed by the de-sludger.



Cyclone

An abbreviated term for a hydro-cyclone, the piece of equipment commonly used to remove sand from the emulsion to avoid centrifuge damage.

Flavedo

The outer colored portion of citrus peel that contains the oil glands.

Albedo

The white inner portion of citrus peel. It contains no oil glands.

Aldehyde

A family of chemical compounds used to indicate overall oil quality – more is better.

Nookatone

The chemical compound that is generally considered to indicate grapefruit oil quality – more is better.

ACUS, ORCUS

An JBT clean-up system that is similar to a CIP (clean-in-place) system. Stands for *Automatic Clean-up System* and *Oil Recovery Clean-up System*.

Caustic

A water-based solution of either sodium hydroxide (most common) or of potassium hydroxide, used for many of the cleaning and sanitation processes in citrus plants.

Wax

A naturally occurring lipid found in the peel of the fruit that precipitates out of some polished citrus oils during storage at cold temperatures.

Winterize

The storage of citrus oils (usually in cone-bottom tanks) under chilled temperatures to allow time for the wax to precipitate and settle out of the oil.

Decanting

The separation of oil and water by gravity in a specially designed tank. Decanting can also be accomplished with centrifuges.

Specific Gravity

Refers to the ratio of the weight of a known volume of a substance compared to the same volume of water at standard conditions.



Immiscible

Incapable of being mixed together. An example is that of oil and water.

Centripetal Pump

A type of pump used as a centrifuge discharge pump whereby the outer volute (casing or housing) of the pump revolves while the impeller of the pump is stationary. Liquid is drawn into pump thorough the volute and discharged through the center of the impeller (an action that is opposite to that of a common centrifugal pump).

Slurry

A thin, watery mixture of a liquid (usually water) and an insoluble material (such as frit).

Essential Oil

An oil that has the characteristic odor of a plant from which it is recovered.



3. Safety Rules

Safety is an important part of everyone's job. Following safety rules and regulations will help to protect yourself and others from serious injury. At JBT Corporation, the safety and personal well being of our employees and our client's employee are of the utmost importance. It is our policy to provide and maintain safe, healthy working conditions and to follow operating practices in support of our policy. We require other employers to do the same while their employees are working on our property. We strongly recommend that all of our client adopt these safety rules for their employees.

The following list of safety rules and procedures is not intended to be all-inclusive. All additional safety rules of your employer should also be observed.

1. Be familiar and comply with all safety rules. Observe and obey all safety signs.
2. When uncertain of the proper way to accomplish a task safely, ask a supervisor to instruct before proceeding.
3. Never change established work procedures without first discussing the safety aspects with a supervisor.
4. Learn from experienced employees; they are familiar with the hazards of the work place.
5. While working with others, make sure they know what actions you are planning to take. Both good teamwork and good communication promote safety.
6. Employees with long hair who work around moving equipment must wear hair restraint and covering.
7. Do not wear rings, beads, bracelets, watches, loose or baggy clothing, or other such items around moving equipment or any other work situation in which they may create a hazard.
8. Hearing protection devices must be worn by all persons who work in, or enter in, a designated Hearing Protection Area.
9. Employees must always be properly dressed while on the job. Tank tops and other sleeveless shirts and blouses shall not be worn at work.
10. Shoes with firm soles and tops must be worn while working. The wearing of sandals, sneakers (tennis or jogging shoes), high-heeled dress shoes, or open toe shoes must be strictly avoided.
11. When operating machinery, never wear gloves. They could get caught in the machine and cause an injury.



12. Employees, who wear contact lenses or who have vision defects, must wear safety glasses at all times while on the job. All employees should wear goggles or full-face shield on all operations where eye or face hazards may exist and always when:
 1. Using a drill press or portable drill motor
 2. Using a cutting torch
 3. Chipping
 4. Grinding
 5. Handling caustics, acid, ammonia, or other hazardous chemicals
 6. Using steam or air for cleaning
 7. Welding (use a welding helmet)
13. Never watch electric or gas welding operations without using proper eye protection. Permanent injury can occur to your eyes.
14. Safety equipment specified by management must be used when working.
15. Life lines and safety belts must be used when high overhead work is being performed. The area underneath must be roped-off and warning signs posted.
16. Personal radios with ear-muffs or head-sets shall not be used while working.
17. Report all on-the-job accidents to management immediately.
18. Report any unsafe condition, machinery, or work practice to management.
19. Safety guards and devices shall not be removed except by authorized personnel. All guards and devices must be put back into place before equipment is placed back into operation.
20. Disconnect, lock out, and tag the main power switch of a machine before attempting repairs.
21. Use hand tools correctly and only for the purpose for which they are designed. Defective tools must never be used.
22. Do not carry sharp hand tools in your clothing. Use proper carrying cases or tool kits.
23. When repair work is being done, care must be exercised to assure the safety of other employees and equipment.
24. Only authorized personnel may remove covers from electrical boxes, breakers, switches, or other electrical devices and controls.
25. Open manholes, floor opening, and excavations must be properly and safety barricaded or roped-off at all times.



26. Do not take shortcuts over or through hazardous areas. Be particularly careful when passing underneath all conveyors, low or overhead.
27. Use handrails when going up or down stairs and steps.
28. Use only ladders that are properly secured and in good condition. Use both hands while climbing.
29. Only authorized personnel shall be allowed onto the roof of any building.
30. Obey posted speed signs at all time.
31. Pedestrian and vehicular traffic must observe established traffic patterns and walkways.
32. Be on the alert for moving vehicles, such as trucks and forklifts.
33. Maintain good housekeeping in your area at all time. Do not place materials in aisles, ramps, stairway, or other paths of travel. Wipe up oil and grease spills promptly.
34. Fire doors, aisles, and exits must remain completely unobstructed at all times.
35. Access to fire extinguishers and fire hoses stations must remain unobstructed at all timea.
36. Fire extinguishers and fire hoses must not be used for any purpose other than emergency use.
37. Employees engaged in welding or using torch must always have a fire extinguisher on hand in case of fire. Fire extinguishers from assigned stations shall not be used for this purpose.
38. Safety helmets (hard hats) shall be worn at all times in designated Hard Hat Areas. Bump caps are not substitute for s hard hat.
39. Never enter a tank, underground drainage opening, or other enclosed and confined area until the air is properly tested for oxygen content and the presence of combustible or toxic gases.
40. Never enter a tank, underground drainage opening, or other enclosed and confined area without an assistant who shall remain outside the opening ready to help in the event of an emergency.
41. Never enter a tank, underground drainage opening, or other enclosed and confined area unless you are attached to a lifeline with its free end held by your assistant outside the opening.



4. System Description

Extraction

The JBT oil recovery system is unique because the juice extractor contains the components necessary to rupture the oil glands and extract the oil into the emulsion. This process minimizes the space and energy for high yields of oil from the peel, at the same time extracting the juice.

Oil extraction occurs in sequence after fruit is placed on lower extractor cup and lower cutter, the upper cup descends, pressing the fruit against the lower cup, and plugs are cut in the fruit. The upper cup descends, forcing the juice and inner fruit contents down through the lower cutter for juice recovery. At the same time, the peel is shredded, being forced through opening in the upper cup, which ruptures the oil glands. The upper cup assembly contains a spray ring, which applies pressurized water to the peel during and after the shredding step, emulsifying the oil as it is released. This emulsion and small particles of peel and soluble and insoluble solids flow from the extractor, are collected and sent to a finisher for initial separation of the larger particles. The finished emulsion is sent to a centrifugation process for concentration and recovery of the final cold-pressed oil.

Frit separation

The frit is separated from the emulsion by either a screw or a paddle finisher in the JBT system. Other system designs may use either a vibrating or gravity-flow screen in place of the finisher. Regardless of the separation method used, it must be gentle enough to prevent the extraction of naturally occurring pectin and hesperidin from the frit particles along with the emulsion. Excessive amount of pectin and/or hesperidin will interfere with the centrifuge process efficiency due to the emulsion viscosity increase.

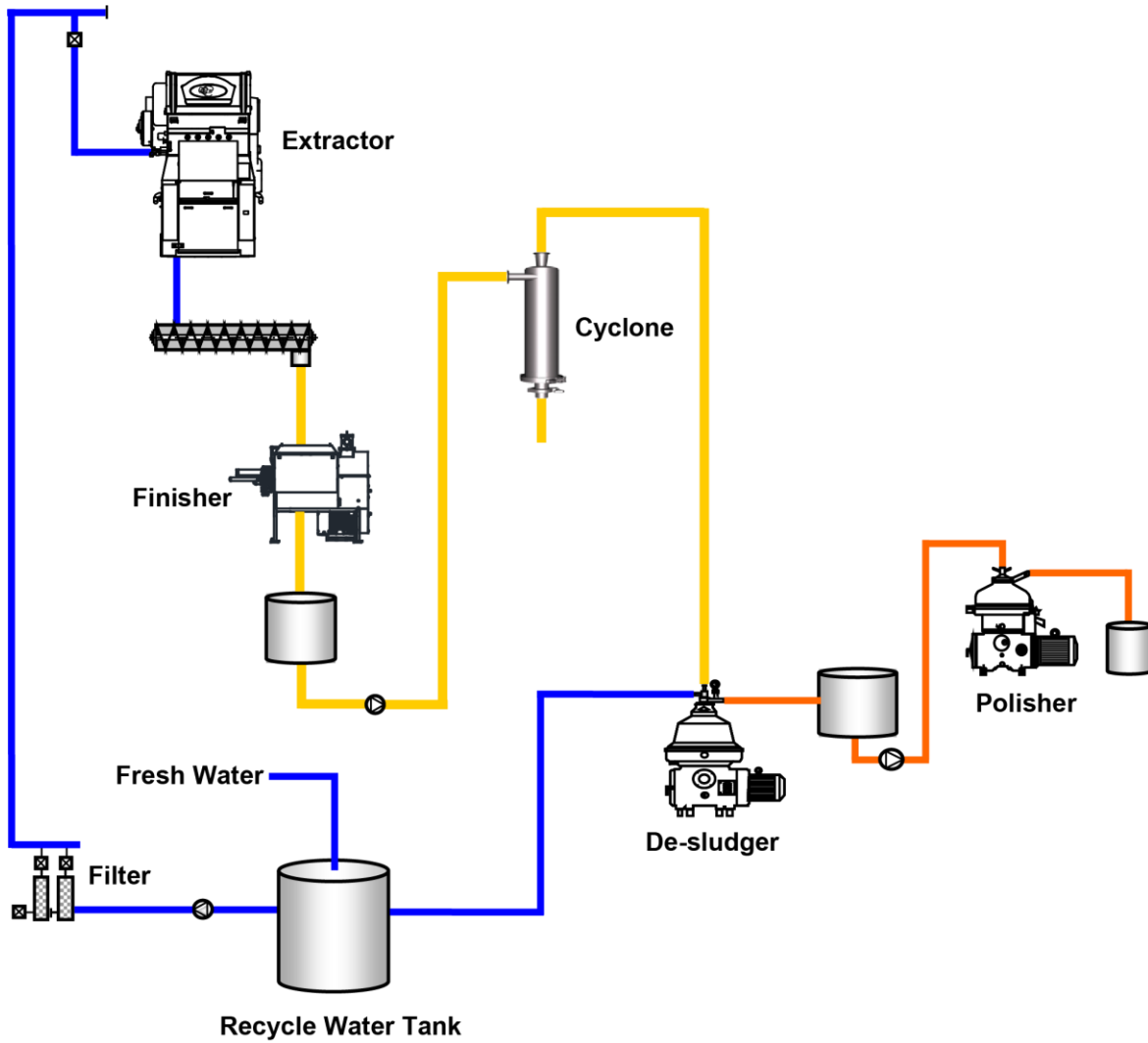

Figure 2 – Typical JBT Oil Recovery System

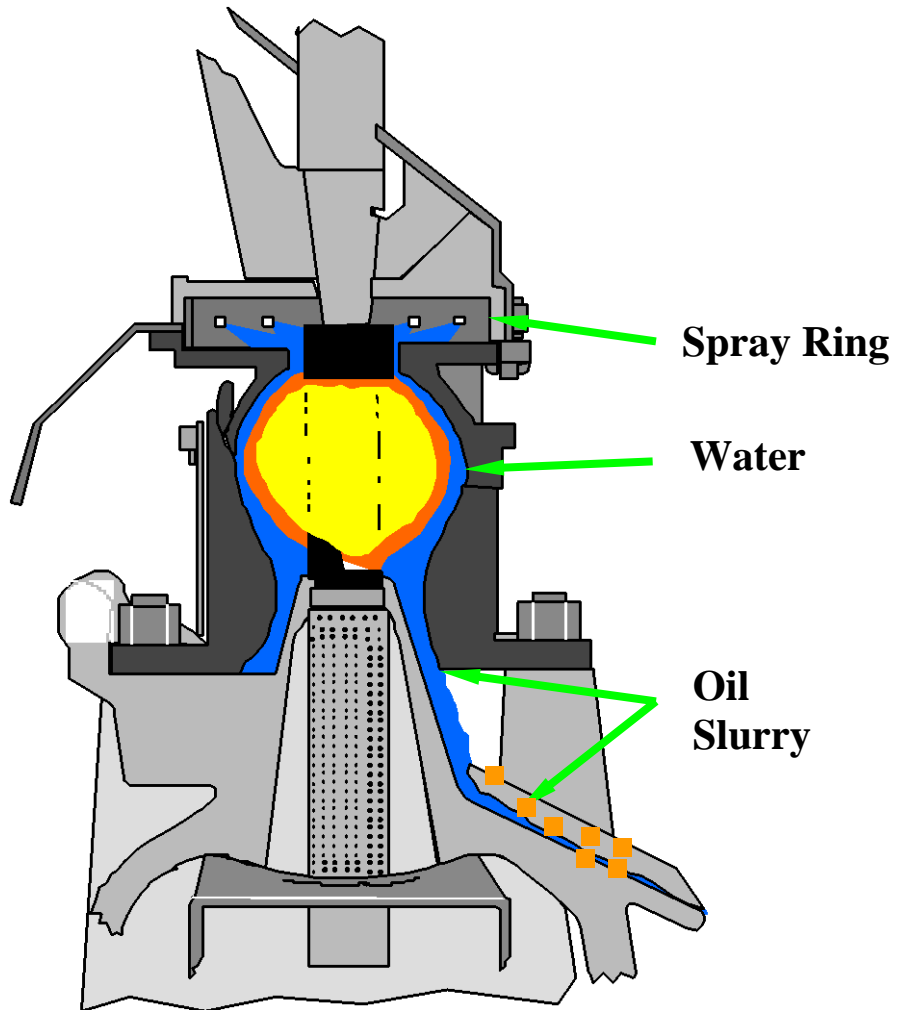

Figure 3 – Application of Water During Extraction



Centrifuge system

To recover the oil from the emulsion, a two-stage centrifuging system is typically required. The first stage centrifuge separates most of the water and solids from the emulsion, producing an oil-rich emulsion commonly called “cream”. The second stage centrifuge is the “polishing” stage where the remaining water and fine peel particles are removed from the “cream”, producing purified oil.

De-waxing / winterizing

One additional operation is usually required before citrus peel oils are sold, a process known as de-waxing or “winterizing”. All citrus oils contain a small amount of a naturally occurring wax. This wax will precipitate out of the oil during storage at cold temperatures and is considered by buyers to be a contaminant. If the oil is used without winterizing in a clear beverage formulation that will be stored and distributed under cold conditions, the wax will cause the beverage to appear cloudy and spoiled.

Winterizing is accomplished by storing the oil in cone-bottom tanks at a cold temperature for a period sufficient enough to allow the wax to precipitate out of the oil to the bottom of the tanks. This process usually takes a minimum of four weeks at storage temperatures of around 32°F. Winterizing can also be done by rapidly chilling the oil to very low temperatures with a chiller, followed by a fine filtering to remove the wax.

Storage

After winterizing, peel oil can be safely stored in sealed drums in an unrefrigerated warehouse if desired. The optimum storage temperature should not exceed 68°F (20°C). It is advisable after prolonged storage times to sample the product before shipping as more precipitate may have formed and additional filtering may be necessary.



5. Water

Source

The initial water source supplying an oil recovery process is very critical to the quality of the finished oil and to the efficient operation of the oil recovery equipment. The water should be pure and free of contaminating chemicals such as caustic, ammonia, and chlorine. These chemicals can affect the flavor and the overall quality of the finished oil. The water should be low in mineral content to reduce scale buildup in the centrifuges. Also, it should be filtered to optical clarity standards (25 microns or smaller) to remove all sand and other particulate matter that may harm the sealing surface of the centrifuges.

Cooled (68°F/20°C) product condensate water from a juice evaporator comes the closest to meeting all of the requirements for producing citrus oil. However, extreme care must be taken to assure that it is not contaminated with caustic or sanitizing cleaning solutions, and has no objectionable flavors or odors.

Although the water should have as low a microbiological count as possible (equal to potable water drinking standards), the cleanliness of the fruit is probably more of an issue as far as bacterial contamination of the oil recovery process is concerned. Refined oil has some bactericidal properties, but the presence of high levels of bacterial contamination during the recovery process can significantly lower the final oil quality.

Water from a feedmill's waste heat evaporator should not be used without additional treatment to improve its purity.

Recycling

Oil recovery involves large quantities of high quality water. Since waste disposal has become a very critical issue in recent years, it is economically necessary to recycle as much of the water as possible (usually 60% to 80%) to reduce waste disposal costs and to minimize environmental issues. It has been found through experience that the amount of water that is normally lost in the system from equipment operation (centrifuge and polisher desludging) as well as that lost with the frit and then replaced from the water source may be sufficient to maintain the efficiency and the quality of the recovery process. The amount of fresh make up water should be in the 20% to 40% range depending on the emulsion quality. If the fruit is over mature, it may be necessary to bleed some of the recycle water and replace it with fresh water. The viscosity of the recycle water should not be bigger than 4 cPs using a standard spindle at 30 RPM (see graphic 1) in order to maximize the desludger efficiency. Increase the viscosity of the recycle water will lower the desludger efficiency.

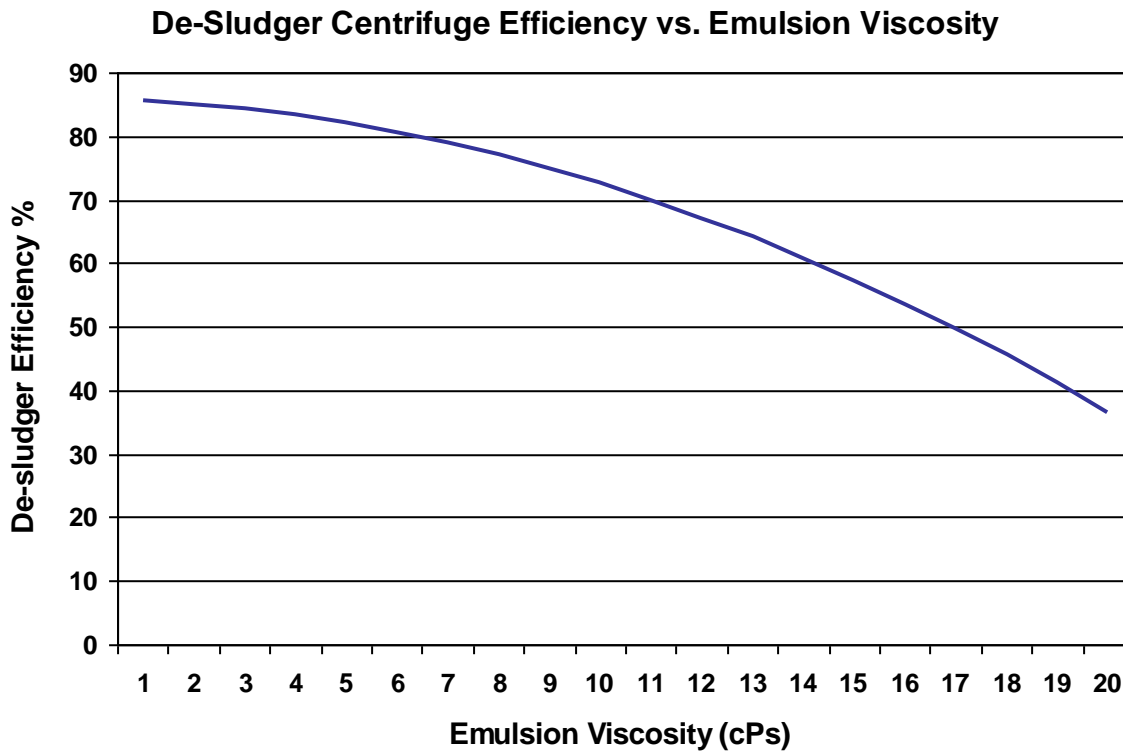

Figure 4 – Desludger efficiency vs. Emulsion viscosity - Centrifuge Alfa-Laval 618

Conditioning

JBT has developed a successful system for cleaning and recycling as much of the water as possible without reducing oil recovery yields or oil quality. To minimize the plugging of the water spray rings in the JBT extractors, the water must be filtered through a fine mesh filter. JBT recommends the use of filter screens with a maximum opening of the 0.009 inches in diameter, which is about the size of a 40 mesh screen. In addition, the use of a horizontal decant tank is recommended to remove light solids.

The water temperature to the extractors should be no higher than 75°F (24°C) or too much pectin, which will interfere with centrifuging efficiency, may be extracted from the frit. Warm water also increases the amount of oil fumes that are generated throughout the process, which leads to a loss of the more delicate aromatic compounds from the oil. **Figure 5** shows the influence of the water temperature upon the oil recovery efficiency at the extractor.

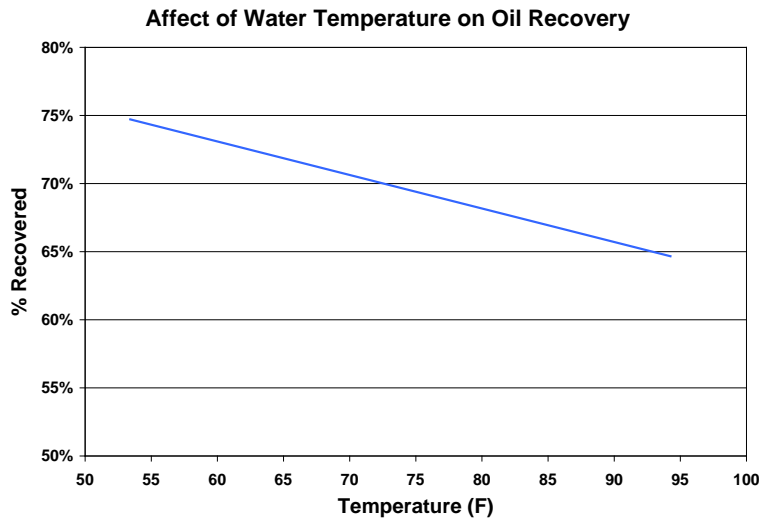

Figure 5 – Oil recovery decreases with increased water temperature

Volume

The volume of the water supplied to the extractors should be maintained at a certain amount to maximize oil recovery efficiency at the extractor while not over-feeding the desludger centrifuges. For orange on a five head extractor the optimal water flow rate has been found to be 6 to 7 gallons per minute. **Figure 6** shows the oil recovery efficiency at the extractor as function of the amount of water applied in the spray rings.

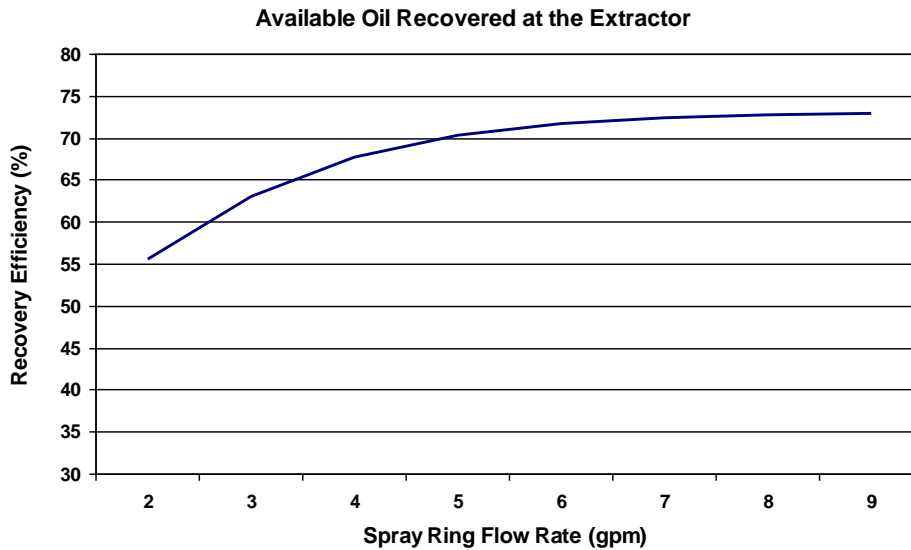

Figure 6 – Affect of water flow on efficiency

6. Centrifuges

*** * SAFETY ALERT * * ***

This manual is not a substitute for a centrifuge manufacturer's manual. Be sure you have read the manual that was supplied with your particular model of centrifuge before attempting to operate, adjust, or service.. Because they operate at high-speeds, careless and inexperienced operation of centrifuges can be extremely hazardous to operators and persons nearby.

Proper centrifuge operation, maintenance and cleaning are the most critical parts of an oil recovery process. Successful peel oil recovery depends upon each operator:

- 1) having an intimate working knowledge of centrifuges,**
- 2) understanding how they operate, and**
- 3) following operational procedures closely.**

Operating principle and design

The principle of operation of a centrifuge is based on the existence of a difference between the specific gravity of the substances being separated. By rotating at high speeds (4,500 to 5,000 rpm), centrifuges apply tremendous centrifugal forces to solutions of two or more immiscible liquids (an emulsion) or slurries of liquids and solids. Under a sufficiently high centrifugal force, a substance with the higher specific gravity will migrate to the outer wall of the spinning centrifuge where it can be collected and discharge separately from the substance with the lower specific gravity.

Figures 7 and 8 are illustrations representing the exterior appearance of two of the common centrifuges used in citrus oil recovery systems. Become familiar with the illustrations even though they may look a little different than your centrifuge. **Figures 9 and 10** represent the internal design and assembly of the typical centrifuges used in citrus oil recovery. The internal parts in your centrifuge are very similar to those shown in these illustrations and the operating principles are the same.

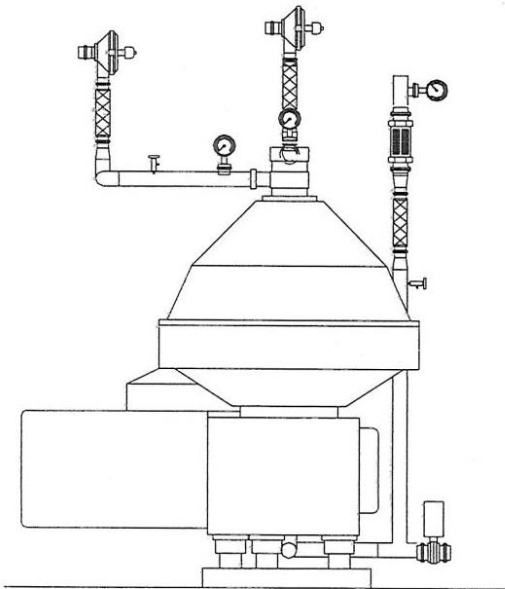

Figure 7 – Alfa Laval Centrifuge

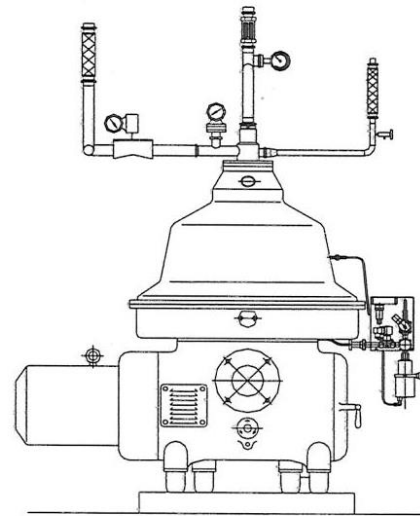
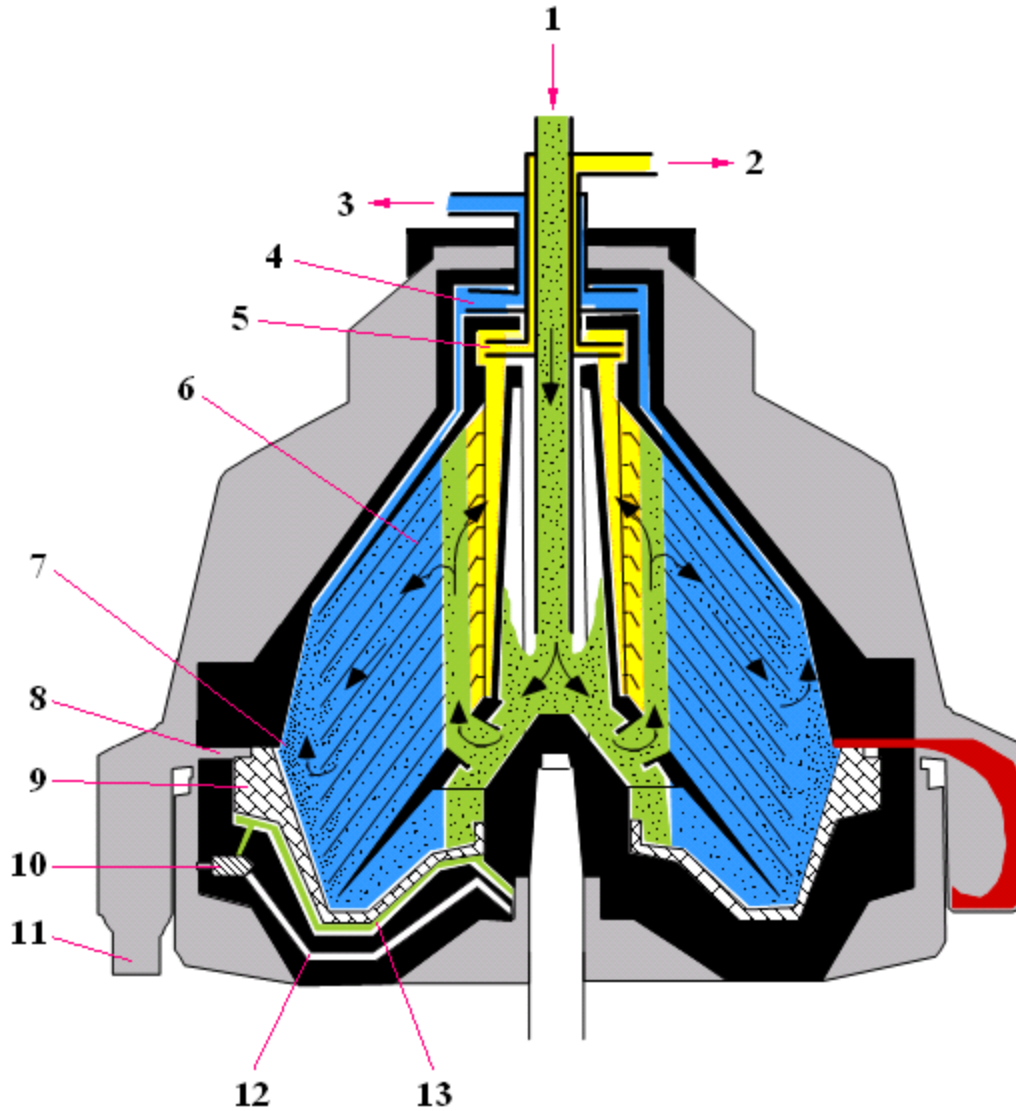

Figure 8 – Westfalia Centrifuge

The disc set (disc stack) is made up from a series of conically shaped parts (discs). The discs are designed to allow the feed emulsion to spread into a thin film, which increases the efficiency of separation. Separation occurs on the underside of each disc, with the heavier liquid and solid material going to the outer edge of the disc and the lighter going to the center of the disc. Solid material that is heavier than water accumulates in the solids holding space at the widest part of the centrifuge bowl.

As the separated oil and water accumulate in the centrifuge bowl, they flow upward to separate discharge points at the top center of the centrifuge bowl. The water travels upward along the outer edge of the disc stack, and the oil travels upward through the center of the stack. Both the water and the oil are discharged from the centrifuge with the aid of separate centripetal pumps.



- | | |
|---------------------------|---------------------------|
| 1 Feed | 8 Sediment election ports |
| 2 Discharge, oil | 9 Sliding piston |
| 3 Discharge, water | 10 Piston valve |
| 4 Centripetal pump, water | 11 Solids discharge |
| 5 Centripetal pump, oil | 12 Opening water duct |
| 6 Discs | 13 Closing chamber |
| 7 Sediment holding space | |

Figure 9 – Centrifuge Internal Design

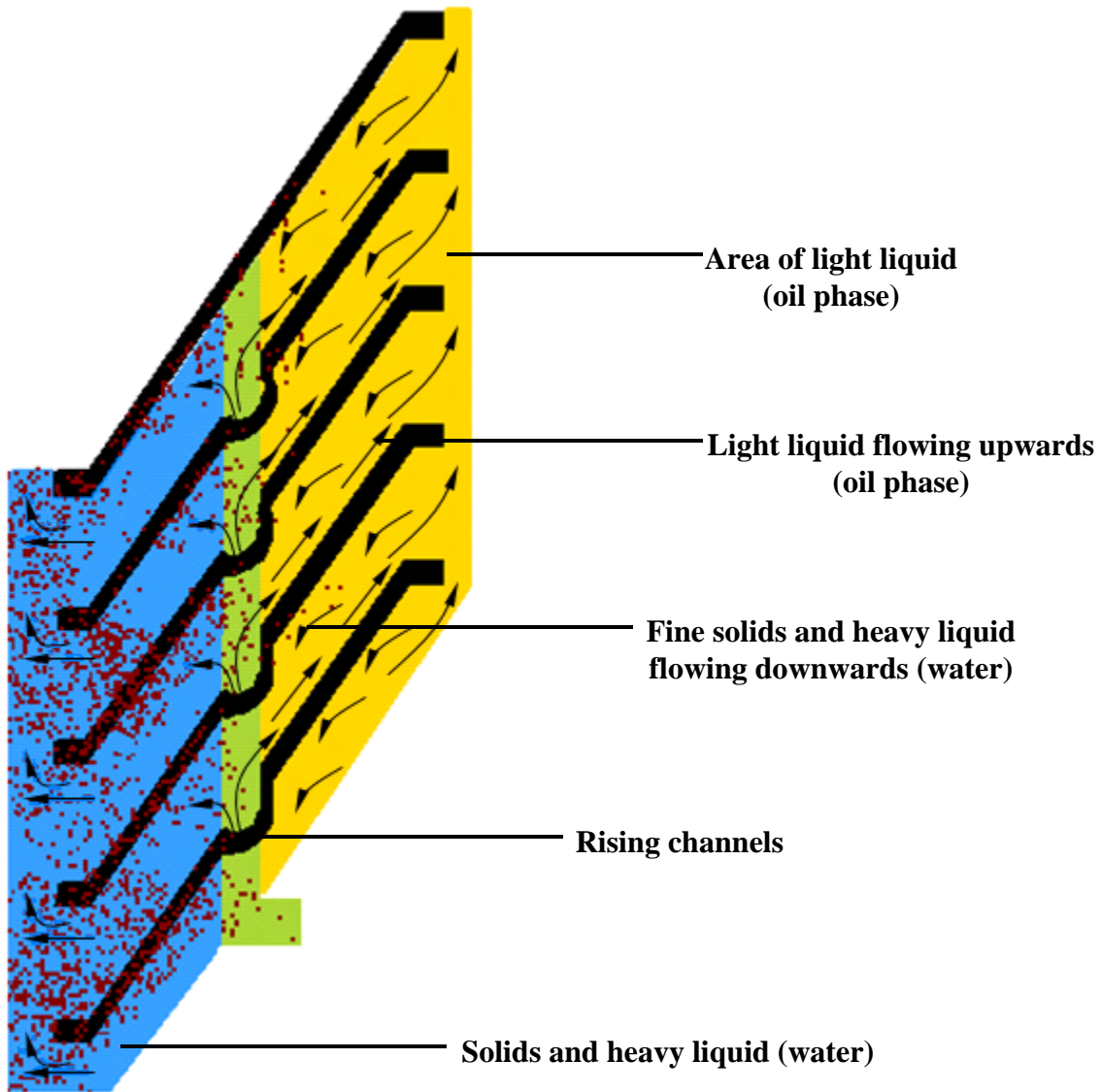

Figure 10 – Effect of Discs during the separating process

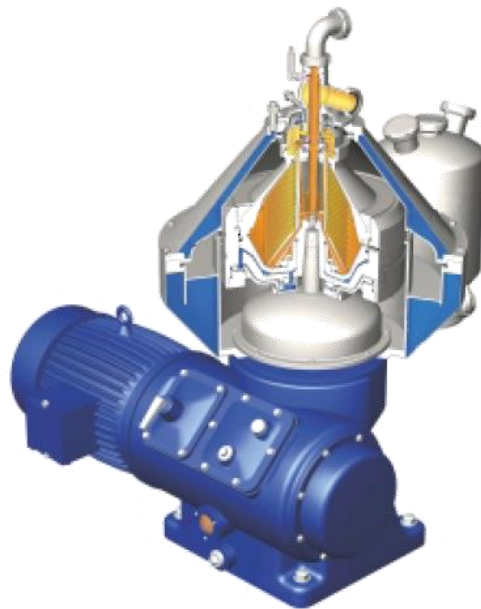

Figure 11 – Desludging Centrifuge – Alfa Laval

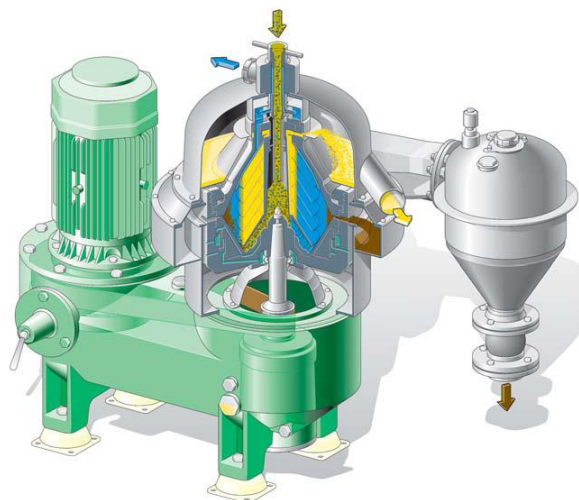

Figure 12 – Polisher Centrifuge – Westfalia OSD

When sufficient solid material has collected in the solids space between the outer edges of the disc set and the inner side of the bowl, the bowl is caused to open, allowing the solid material to be discharged. In a properly adjusted and operating centrifuge, this usually occurs without requiring the feed liquid to stop flowing, and it occurs so quickly that the liquid phase stays within the bowl. The actual opening clearance of a typical centrifuge bowl is only about 5 mm (0.2 inches). Depending on the centrifuge model, about 3 to 5 gallons would be discharged for a partial shooting during the bowl opening or about 12 to 20 gallons for a total shooting, when all the liquid in the centrifuge is discharged during the bowl opening cycle.

System configuration

A two-stage centrifuge system is required to recover citrus oil efficiently. The first stage removes most of the water and insoluble solids from the emulsion. This stage may involve more than one desludging centrifuge, depending upon the volume being processed. The oil-rich emulsion (cream) produced by this centrifuge should have an oil ranging between from 65% to 85% (and preferably >75% for best results). This oil-rich cream becomes the feedstock for the second stage polishing centrifuge.

The second stage polishing centrifuge is where the remaining water and some cloudy particles are removed. The oil discharged from this stage product and is ready for winterizing and storage.

Figure 13 is a cut-way drawing of a typical polishing centrifuge. Except for being physically smaller and operating at a much higher RPM, it is much the same internally as the desludging centrifuges.

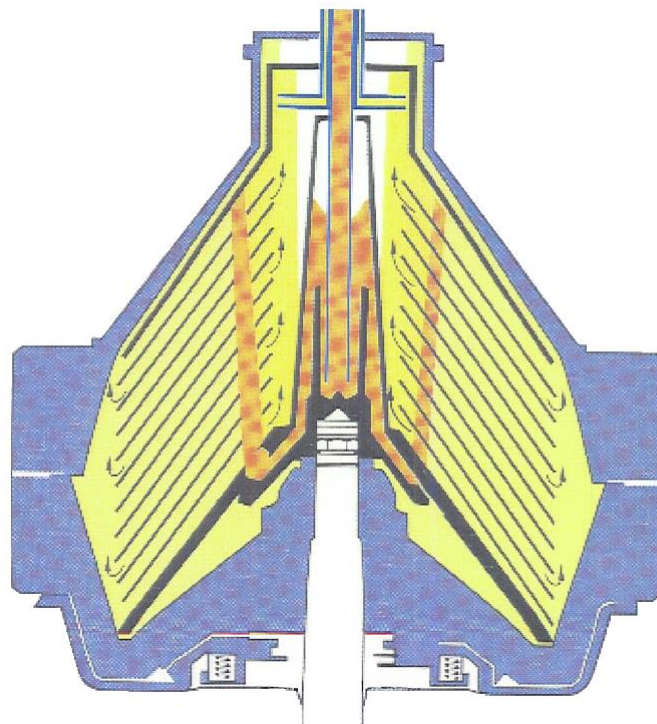

Figure 13 – Polishing Centrifuge Cut-Away



7. System Operation

Because there are so many different designs of oil recovery systems, it is impossible to provide detailed instructions for each system in one manual. Therefore, this manual assumes that the operators have received specific training for the system and the equipment in their plant.

Startup responsibilities

First and always, before any equipment is started, perform a thorough visual inspection of the complete oil recovery system for safety and sanitation purposes. Never start any equipment without this step, and never assume that it has been done by anyone else without specific communications with that person.

Operators responsible for starting the oil recovery system have a serious responsibility to make sure they are not going to carelessly cause injury to another person or cause equipment damage. This is especially critical where systems are being remotely controlled with computers. A few minutes production time saved is not worth the risk of an injury.

Visual inspection

The first thing to do before starting any equipment is to take a thorough visual inspection of the complete oil recovery system. Make sure all safety guards and equipment covers are in place. Close all drain valves and set all divert valves to their correct operating positions.

Startup Checklist

Use the checklist that has been prepared for your specific oil recovery system and furnished as part of this manual to be sure nothing is overlooked. When you have checked all items on the list and assured that the system is ready for operation, then place the system into operation.

Initial operations

First, turn on the desludging centrifuge and the polisher, following the manufacturers recommended procedures, and let them come up to speed. These may take up to 30 minutes to reach their correct operating speeds. Pay close attention to the sound of the desludging centrifuge and the polisher as they gain speed. If unusual noises are heard or an unusual vibration is noticed shut off the equipment immediately and notify your supervisor.

After the centrifuge and polisher are up to speed, you can begin operation. Usually, water is first supplied to the centrifuge and the polisher, and the controls are checked to assure satisfactory operation, before you begin oil recovery operations.

The preceding steps should be completed by the time the extractors are ready to begin operations so oil recovery yields can be optimized. As the extractors begin, be sure that the mixture of the frit and oil-water emulsion is flowing properly to the frit removal system. Also, assure that the recovery water to each of the spray rings on the extractors is flowing properly.



Startup adjustments

When the emulsion supply tank is at its normal operating level, begin sending the emulsion to the centrifuge. Adjust the centrifuge feed rate to get the best oil efficiency separation in the centrifuge. Each model of the desludging centrifuge has an optimum feed rate. During the first 10 minutes of centrifuge operations, put enough backpressure on the oil-rich emulsion discharge to accumulate the oil inside the centrifuge and then open the valve gradually as needed to achieve proper separation of the emulsion. Check the adjustments frequently until you are satisfied that the centrifuge is operating normally.

When a sufficient quantity of oil-rich emulsion has accumulated in the polisher tank, begin sending the “cream” to the polisher. Closely monitor the clarity of the oil as it is discharged from the polisher. It should be of the proper color (as described previously), and it should not be cloudy. Cloudy oil will have to be recycled back through the polisher. Do not allow it to contaminate your good, clear oil in the storage tank. Also, collect some discharged sludge and centrifuge it to verify if there is no free oil in the sludge. If any free oil was found, adjust the polisher shoot time.

Sand separation

A good sand separation system will protect the centrifuges from premature wear. A good maintenance program should include regular monitoring of the sand separation cyclones on the feed line to the centrifuge. Do not allow sand to accumulate in the cyclone; dump it frequently. Allowing sand to pass into the centrifuge can cause the bowl seals to wear out quickly, and it can damage the metal sealing surfaces of the centrifuge bowl.

Operational adjustment

During system operation, you will have to make periodic adjustments to the centrifuge operating controls. This is necessary because a change in the fruit can affect the amount of oil in the oil-rich emulsion, or because the system is beginning to build up a residue from the emulsion that can change the separation efficiency of the centrifuge.

The water flow to the extractor will need to be readjusted if the fruit extraction rate changes significantly for a prolonged time. It may also require readjusting as some of the solids residue remaining in the recycle water builds up in the spray ring hole due to the recycle water viscosity increase.

Other adjustments to the system will depend upon the particular system design in your plant and the checklist included in this manual should be reviewed for additional adjustment guidelines. Once the system is up and running in a balanced mode, very little operator changes should be required. Generally, operators need only to follow the checklist guidelines to be sure no event has occurred that will interfere with efficient operations.



Operating Checklist

1. At the beginning of each shift, and again at midshift, assure that the oil recovery water flow is adjusted properly to each extractor and that none of the spray rings are plugged. Inspect the oil chute at the rear of the extractor. Frit and water flow should be even across the chute. If dry spots are observed, this may indicate that spray rings are plugged.
2. Assure that there are no leaks throughout the oil recovery system piping.
3. Assure that the “blowdown” valve on the desludger middle-phase water discharge line is adjusted so a minimum of 20% fresh water is always flowing into the recycle water tank.
4. Maintain the timing of the “shoot” cycle of the desludger at the maximum setting which will not lower desludging efficiency. This will normally be in a range of from 1 to 6 minutes.
5. Check and log the oil content of the discharge line of the desludger twice per shift, using the spin test procedures. The cream discharge should test at about 70% or greater oil content.
6. Check and log the centrifuge efficiency at least once per shift. Using the Scott Test, verify the oil content in the in feed emulsion and the middle phase water. Typically, the in feed oil content should test between 1% to 3% and the recycle water phase less than 0.25%. Values substantially different than these are generally an indication of an operating adjustment problem.
7. Check and log the pH of the feed emulsion at the beginning of each shift and immediately after a restart from ACUS and ORCUS cleaning procedures. The pH should be close to 7, indicating that there is no caustic remaining in the system.
8. Check and log the viscosity of the feed emulsion to determine the recycle water quality. A viscosity value greater than 4 cPs indicates that the recycle water quality needs improvement, adding more fresh water to the system and adjusting the decant tank to skim more recycle water.



8. Cleaning

*** * SAFETY ALERT * * ***

Follow all safety procedures of your company when cleaning equipment with hot caustic solutions.

Serious injury can result from the careless handling of hot cleaning solutions.

Proper cleaning of an oil recovery system, particularly the centrifuges, is extremely important to maintain optimum yields. Clean-up of oil system not equipped with JBT ORCUS (Oil Recovery Clean-Up System) is largely a manual operation and it requires proper operator interaction to be sure that the system is cleaning properly, and to prevent contamination of the finished oils with caustic solutions.

Frequency

An oil recovery system should receive a thorough cleaning in most cases at least once every 12 hours of continuous production for the desludging centrifuge (preferably every 10 hours) and 24 hours for the polisher. See the **Figure 14**. Cleaning should also be redone before starting production if the system has been down for 6 hours or more. More frequent cleanups are required under some unusual operating conditions or with certain citrus varieties, or changes in fruit condition. The need for changing the frequency of cleaning is best determined by specific observation of a particular system.

Cleaning solutions and temperatures

The following guidelines should always be followed as closely as possible.

1. Caustic solutions should be heated to minimum of 160° F (70° C) for best results. The solution strength should be a minimum of 2%. A stronger solution strength may be needed under some circumstances. Departures from the normal 2% should be specifically written into the check-list cleaning guidelines for your plant.
2. Caustic cleaning solutions should be circulated at a higher flow rate than the normal operating process for a minimum of 20 minutes (30 minutes preferred) through the centrifuge and the polisher to assure proper cleaning. Improper cleaning can cause a large loss of operational efficiency for the centrifuge and the polisher, and can result in lower quality oil.
3. When the plant water source is high in dissolved mineral content, some scaling of the internal parts of the centrifuges will be experienced. In such cases, it will be necessary to periodically disassemble the centrifuges and polishers for manual cleaning. Ignoring this issue will result in lower efficiencies.

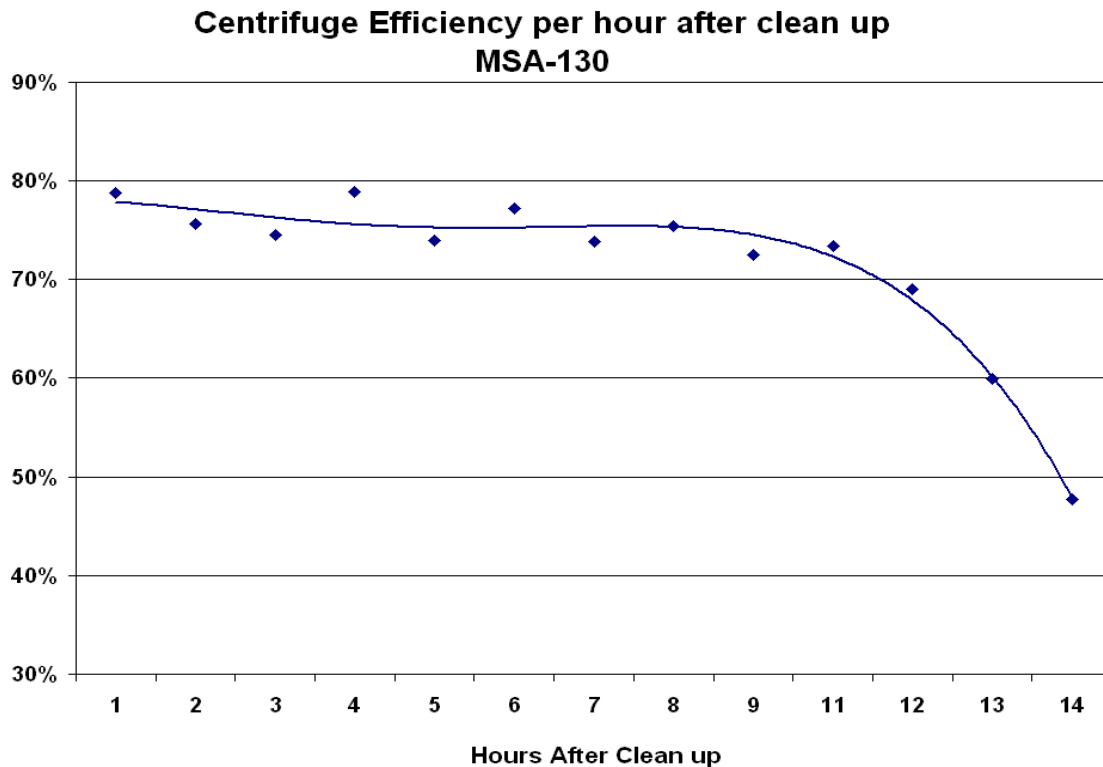

Figure 14 – Centrifuge Efficiency per Hour after Clean-up – Orange Fruit

Clean-up procedures

The oil recovery operators should be informed by the plant supervisors of the scheduled time of processing startups, and of scheduled and non-scheduled cleanups. At the moment the clean-up starts and the fruit ceases to enter the extractors, the oil recovery operator should turn off the water recycle pump, but continue to process the remaining oil emulsion and the cream until the tanks are empty. Although another crew may have responsibility for cleaning the oil finishers, emulsion tanks, and pipe lines as a part of the extraction clean-up, the oil recovery operators should coordinate that part of the clean-up. They should assure that the equipment is thoroughly rinsed to remove all traces of caustic from both the outside as well as the inside of the equipment. When the oil emulsion and the cream tanks are emptied, the clean up of the centrifuges and associated equipment can begin.

Established clean-up procedures vary from plant to plant, but usual procedures call for a 10 minute water rinse cycle, followed by 20 to 30 minutes of hot caustic cleaning, with another 10 minute cycle of clean water rinsing. In a plant with an ORCUS system, all these steps are controlled by a computer. Periodically, the QC laboratory should take bacterial swabs of the equipment to test for cleaning effectiveness. Changes to established cleaning procedures should only be considered after such test data has been analyzed.



9. Equipment Disassembly

**** SAFETY ALERT ****

WARNING: Do not attempt to disassemble any powered equipment until you have followed all safety lockout/tagout rules of your company, and have been specifically trained in the proper techniques to disassemble and reassemble the equipment by a qualified technician. Serious injury may result from careless and improper assembly of high-speed rotating machinery.

Periodically, it is necessary to disassemble the centrifuge and the polisher for a manual cleaning and inspection of internal parts. The frequency of this disassembly is dependent upon many variables, but you should begin by following the recommendations of the centrifuge and polisher manufacturers.

Use care when you remove parts from the centrifuge. Do not lay them on a bare concrete floor where they can become scratched up or otherwise damaged. Store the parts on wooden pallets or tables, both before and after cleaning. Do not carelessly bang the parts against other parts or equipment. When reassembling the parts, do not use excessive force to refit those parts: if it will not go together reasonably easy, find out why and correct the problem. *Again, use caution.* Improperly assembled, high speed rotating machinery such as centrifuges can catastrophically fail and come apart if assembled incorrectly, with disastrous results.

Shutdown preparations - Short-term

When shutting down an oil recovery system, a thorough clean-up is necessary following the cleaning procedures in the checklist that has been prepared for your system.

If the system is to remain out of production for 8 hours (1 shift) or more before resuming operations, additional precautions should be taken to prevent insect and rodent intrusion.

Turn off all electrical powers to the system using the motor control disconnect switches. Be sure to lock out or tag out the switches so another employee will not accidentally energize the equipment.

Close and secure all centrifuge access covers and surge tank covers. If covers are not installed, cover the openings with plastic film and secure with masking tape. Assure that all water and compressed air valves are closed. Close all drain valves and reinstall drain caps (if furnished).

For longer shutdown periods (1week or more), the outside on the centrifuges and the inside and outside of the surge tanks and sludge troughs should be dried, either with clean rags by hand, or by blowing compressed air to remove as much moisture as possible. This step will prolong the appearance of your equipment and will also minimize the growth of molds and mildew.

Shutdown preparations - Long-term

For long-term shutdown periods, such as during the off season months, the centrifuges and the polishers should be disassembled, inspected, and repaired, and the parts safely stored in a clean, dry area until operations resume. Drive motors and other opened equipment should be protected with a plastic wrap to keep them clean, dry and insect free.



10. Operational Logs and Report Examples

Good record keeping is essential to assure efficient operations and for troubleshooting purposes. The examples on the following pages are recommendations as a starting point and can be modified to suit the particular needs of your system.

As a general rule, operating logs and reports should be as brief as possible. Neatness is important when entering data in logs and reports. Your company may retain some paperwork for several years. Write clearly, print all letters and numerals. When required, sign your name or your initials legibly, and always include the date on every page.

Use a ball-point ink pen for all entries. Do not use a pencil or non water-resistant fiber tip pens.

Always enter data at each reporting period during your shift. Do not wait until the end of the shift to try to catch up on your paperwork. Chances are you will not be able to remember everything and important information may be lost.

Keep all of your paperwork in a clean, dry, orderly condition.



Summary of Plant Performance

Week of _____

Day	Boxes of Fruit Run	Tons of Fruit Run	Inches of Oil to Tank	Pounds of Oil	Pounds per Ton	Remarks
Mon.						
Tue.						
Wed.						
Thur.						
Fri						
Sat.						
Sun.						

Average available oil in fruit (lbs/ton) for the week: _____ (lb/ton)

Recovery as a percent of the available oil: _____ (%)



11. Efficiency Calculations

Measuring the efficiency of oil recovery operations is necessary to assure that the equipment is not only being operated properly, but also to determine whether or not the system is capable of recovering oil at its design capacity.

Efficiency calculations require a series of detailed, laboratory-conducted measurements to be accurate. Because of the amount of work involved, these measurements are usually conducted periodically rather than routinely. They must be done often enough, however, to provide an accurate basis for efficient operations.

Without knowing how much oil is actually available from the fruit, it is impossible to determine a true operating efficiency. As the table on the following page shows, the range of total oil available in Florida fruit varies widely between varieties, and even within a single variety. This makes it impossible to accurately compare oil recoveries with other plants or from period to period within a single plant by looking at just the total oil recovered. A frequent and accurate analysis of the oil content in the whole fruit is required.



PEEL OIL CONTENT OF MAJOR FLORIDA CITRUS CULTIVARS

Cultivar	Pounds of Oil per Ton of Fruit	Kilos per Metric Ton
Early Orange	6 – 10	3.0 – 5.0
Pineapple Orange	8 – 12	4.0 – 6.0
Florida Valencia Orange	10 – 15	5.0 – 7.5
Temples	6 – 10	3.0 – 5.0
Seeded Grapefruit	4 – 7	2.0 – 3.5
Seedless Grapefruit	5 – 8	2.5 – 4.0
Red or Pink Grapefruit	5 – 9	2.5 – 4.5
Early Tangerines	3 – 7	1.5 – 3.5
Dancy Tangerines	10 – 20	5.0 – 10.0
Tangelos – Orlando	9 – 13	4.5 – 6.5
Persian Lime	7 – 10	3.0 – 5.0
Lemon – Florida True	10 – 23	5.0 – 11.5

Note: The ranges are for grove run fruit picked and processed within 36 hours. Packinghouse eliminations or fruit held for several days may be lower in oil the minimum figures given in the range.

Source: Kesterson, J.W. & Braddock, R.J. Journal of Food Science (40) 1975



12. Quality Control and Laboratory Procedures

A quality control program for the oil recovery operation is very important. Routine and continuous analysis of the oil emulsion, the cream, and the total oil available from the fruit have been shown to substantially increase the overall yield as these factors increase the awareness of the operating parameters and, therefore, assist in optimizing the operating conditions. The details of these are given below. Also, there are a number of analyses on citrus oil, while not routinely done, those significantly add to the marketing program and, therefore, are very worthwhile. These include such determinations as the aldehyde content, optical rotation, GC profile, refractive index, the physical constants of a 100% distillate, and many other tests.

The following test schedule is recommended

Stream to Analyze	Test to Conduct	Test Frequency
Fruit	Available oil	Once a day
Oil Emulsion (Oil In)	Oil content	Once every four hours
	Centrifuged Solids	Once every two hours
Water phase (Oil Out)	Oil content	Once every four hours
	Centrifuged Solids	Once every two hours
Sludge	Oil content	Once every four hours
Cream	Oil content	Once every two hours
Polisher aqueous discharge	Oil content	Once every four hours
Polisher solids	Oil content	Once a day

The methods set forth in the JBT Corporation “Procedures for Analysis of Citrus Products” should be utilized for the above analyses.



Desludger Centrifuge Efficiency

The calculation for the centrifuge efficiency is: the percent Oil In *minus* the percent Oil Out *divided* by the percent Oil In *times* 100

$$\frac{\% \text{ OIL IN} - \% \text{ OIL OUT}}{\% \text{ OIL IN}} \times 100 = \% \text{ Efficiency}$$

While the centrifuge efficiency may vary somewhat depending upon the model of the desludger, 80% is a reasonable target for oranges; however, for grapefruit and lemon, efficiencies of 95% or greater are desired because of the value of those oils. Anything less than this would be cause to review and consider the operating parameters currently being used (for example: the amount of water going to the extractor, emulsion viscosity, and the desludger centrifuge flow rate). Also, a marked drop-off in efficiency may indicate a problem in the desludger itself, either a mechanical problem or a need for cleaning.

The operator should first obtain small representative samples of the desludger feed (e.g. 100 ml) and then within 1 minute, a similar representative sample of the cream. Care should take to collect the samples several minutes before or after the shoot cycle, but not during the cycle. After proper labeling, the samples should be taken to the lab and analyzed within 1 hour or less.



Typical Daily Quality Control Worksheet

Date: ___/___/___

(Assumes 2 desludgers)

Time	# 1 Deslugger Flow rate	# 2 Deslugger Flow rate	# 1 % Oil In	# 2 % Oil In	# 1 % Oil Out	# 2 % Oil Out	# 1 Effic.%	# 2 Effic.%	Remarks



Oil Analysis of Fruit and Byproducts Procedures

1. Whole Fruit Available Oil

I. Apparatus

- 4-Liter blender (low speed, 15,000 rpm; high speed, 20,000 rpm)
- Optional: 48-Liter vertical cutter/mixer (1800 rpm) with wave cut knives and a mixing baffle
- See Recoverable Oil in Chapter IV of Procedures for Analysis of Citrus Products

II. Chemicals

- See Recoverable Oil in Chapter IV of Procedures for Analysis of Citrus Products

III. Reagents

- See Recoverable Oil in Chapter IV of Procedures for Analysis of Citrus Products

IV. Procedure

1. Collect a representative bulk sample (20.4 kg / 45 lb) from fruit lot during or within 12 hours of receiving. (This can be the same bulk sample for the fruit characteristic analysis). Fruit needs to be pulled from the same location consistently for this test to eliminate causing variation.
2. If needed, count the number of fruit to estimate fruit number per 90-lb box.
3. Obtain randomly 16 fruit from the bulk sample by blind picking, shaking the fruit before each picking, and return the rest of the fruit for processing.
4. Cut each of the 16 fruit into 4 quarters with a sharp knife from the stem to the blossom end.
5. Keep one quarter from each fruit and discard the rest.
6. Weigh the 16 quarters to the nearest 0.1 g.
7. Place the quarters in the 4-liter (1-gallon) blender.
8. Add an equal weight of cold water (2~7° C/35~45° F) and cover the blender.
9. Blend for 3 min at low speed and, then, 1 min at high speed.
10. Place a 500 ml distillation flask on a balance and tare.
11. While the blender is running, carefully transfer about 5 g (~6 ml) of the emulsion into the distillation flask with a plastic disposable pipette.
12. Weigh sample to the nearest 0.01 g.
13. Determine the emulsion oil content using 0.0247 N potassium bromide-bromate solution as titrant as in Recoverable Oil (Chapter IV of Procedures for Analysis of Citrus Products).

Note: For lemon fruit, fruit homogenate is recommended to be prepared by bending 9 kg (20 lb) of fruit with equal weight of water for 10 min in a 48-Liter vertical cutter/mixer.



V. Calculations

1. The fruit available oil is calculated based on 1 ml of 0.0247 N KBrO₃-KBr solution equates 0.0010 ml of d-limonene (Titrant Oil Equivalent) and oil specific weights of 0.840 g/ml for orange, 0.850 g/ml for grapefruit, lemon and tangerine and 0.880 g/ml for lime (see also Chapter IV).

Available Oil (g/g fruit)

$$\begin{aligned}
 &= \frac{\text{Oil Weight in Fruit Homogenate}}{\text{Fruit Weight in Fruit Homogenate}} \\
 &= \frac{(\text{Titrant Volume}) (\text{Titrant Oil Equivalent}) (\text{Oil Specific Gravity})}{(\text{Fruit Homogenate Weight}) \text{ Fruit Content in Fruit Homogenate}} \\
 &= \frac{(\text{Net ml Titrant}) (\text{Titrant Oil Equivalent}) (\text{Oil Specific Gravity})}{(\text{g Fruit Homogenate}) \left\{ \frac{(\text{g Fruit})}{(\text{g Fruit}) + (\text{g Water})} \right\}} \\
 &= \frac{(\text{Net ml Titrant}) (\text{Oil Specific Gravity})}{(\text{g Fruit Homogenate})} \times 0.002
 \end{aligned}$$

Or

$$\text{Available Oil (kg/MT fruit)} = \frac{(\text{Net ml KBrO}_3 - \text{KBr}) (\text{Oil Specific Gravity})}{(\text{g Fruit Homogenate})} \times 2$$

$$\text{Available Oil (lb/ST Fruit)} = \frac{(\text{Net ml KBrO}_3 - \text{KBr}) (\text{Oil Specific Gravity})}{(\text{g Fruit Homogenate})} \times 4$$

Where:

$$(\text{Net Titrant Volume}) = (\text{ml Titrant for Samples}) - (\text{ml Titrant for Blank})$$



- For orange fruit

$$\begin{aligned}\text{Available Oil (kg/MT fruit)} &= \frac{(\text{Net ml KBrO}_3 - \text{KBr})(0.840 \text{ g/ml})}{(\text{g Fruit Homogenate})} \times 2 \\ &= \frac{(\text{Net ml KBrO}_3 - \text{KBr})}{(\text{g Fruit Homogenate})} \times 1.68\end{aligned}$$

$$\text{Available Oil (lb/ST Fruit)} = \frac{(\text{Net ml KBrO}_3 - \text{KBr})}{(\text{g Fruit Homogenate})} \times 3.36$$

- For grapefruit, lemon, and tangerine fruit

$$\begin{aligned}\text{Available Oil (kg/MT fruit)} &= \frac{(\text{Net ml KBrO}_3 - \text{KBr})(0.850 \text{ g/ml})}{(\text{g Fruit Homogenate})} \times 2 \\ &= \frac{(\text{Net ml KBrO}_3 - \text{KBr})}{(\text{g Fruit Homogenate})} \times 1.7\end{aligned}$$

$$\text{Available Oil (lb/ST Fruit)} = \frac{(\text{Net ml KBrO}_3 - \text{KBr})}{(\text{g Fruit Homogenate})} \times 3.40$$

- For lime fruit

$$\begin{aligned}\text{Available Oil (kg/MT fruit)} &= \frac{(\text{Net ml KBrO}_3 - \text{KBr})(0.850 \text{ g/ml})}{(\text{g Fruit Homogenate})} \times 2 \\ &= \frac{(\text{Net ml KBrO}_3 - \text{KBr})}{(\text{g Fruit Homogenate})} \times 1.76\end{aligned}$$

$$\text{Available Oil (lb/ST Fruit)} = \frac{(\text{Net ml KBrO}_3 - \text{KBr})}{(\text{g Fruit Homogenate})} \times 3.52$$



2. For Analyses with accurately weighed samples, the following equations can be used:

- For 5 g of orange fruit homogenate

$$\text{Available Oil (kg/MT fruit)} = (\text{net ml KBrO}_3 - \text{KBr}) \times 0.336$$

$$\text{Available Oil (lb/ST fruit)} = (\text{net ml KBrO}_3 - \text{KBr}) \times 0.660$$

- For 5 g of grapefruit, lemon, or tangerine fruit homogenate

$$\text{Available Oil (kg/MT fruit)} = (\text{net ml KBrO}_3 - \text{KBr}) \times 0.340$$

$$\text{Available Oil (lb/ST fruit)} = (\text{net ml KBrO}_3 - \text{KBr}) \times 0.680$$

- For 5 g of lime fruit homogenate

$$\text{Available Oil (kg/MT fruit)} = (\text{net ml KBrO}_3 - \text{KBr}) \times 0.352$$

$$\text{Available Oil (lb/ST fruit)} = (\text{net ml KBrO}_3 - \text{KBr}) \times 0.704$$

VI. Reference

Official Methods of Analysis. 1999, 16th edition, 5th reversion, AOAC International, Gaithersburg, MD. Method 968.20, 939.12, and 947.13



Table VI – 1. Normal peel oil level in citrus fruits grown in Florida

Cultivars	(lb/ST)	(kg/MT)
Hamlin orange	6 – 10	3.0 – 5.0
Parson Brown orange	7 – 12	3.5 – 6.0
Pineapple orange	8 – 12	4.0 – 6.0
Valencia orange	10 – 15	5.0 – 7.5
Temples orange	6 – 10	3.0 – 5.0
Duncan grapefruit	4 – 7	2.0 – 3.5
Marsh grapefruit	5 – 8	2.5 – 4.0
Ruby Red grapefruit	5 – 8	2.5 – 4.0
Dancy tangerines	10 – 20	5.0 – 10.0
Orlando tangelos	9 – 13	4.5 – 6.5
Persian Lime	7 – 10	3.5 – 5.0
Lemon	10 – 23	5.0 – 11.5

Source: Kesterson, J.W. & Braddock, R.J., 1975. Total peel oil content of the major Florida citrus cultivars. Journal of Food Science 40:931 - 933



2. Recoverable Oil in Oil Recovery System and Juice

I. Apparatus

- 4-Liter blender (low speed, 15,000 rpm; high speed, 20,000 rpm)
- See Recoverable Oil in Chapter IV of Procedures for Analysis of Citrus Products

II. Chemicals

- See Recoverable Oil in Chapter IV of Procedures for Analysis of Citrus Products

III. Reagents

- See Recoverable Oil in Chapter IV of Procedures for Analysis of Citrus Products

IV. Procedure

1. Collect a representative bulk sample at the desired processing points in the approximate quantities shown in table VI – 2A.
2. Mix samples well and prepare analysis samples as shown in Table VI – 2B.
3. Weigh each sample accurately into a boiling flask while under stirring. The normal samples sizes at different oil recovery stages are shown below:

Original, Blended, or Diluted Samples	Analysis Sample Size	
	0.0247 N Titrant	0.1000 N Titrant
Juice	25 g	
Peel, Core, Frit, or Pulp		15g
Oil emulsions		2 g
Desludger or Breaker heavy phase		25 g
Desludger or Breaker sludge		10 g
Desludger light phase		0.1 g
Breaker light phase		0.05 g or 5 g of dilution solution
Polisher heavy phase		2 g
Polisher sludge		0.1 g
Polisher light phase		0.05 g or 5 g of dilution solution



The proper sample size can be determined using the following equation based the approximate/expected oil level in the sample and the using of 0.100 N KBrO₃-KBr as titrant. In most cases, the titrant volume used should be in the range of 5 to 10 ml.

$$\text{Approximate Sample Size (g)} = \frac{3}{\text{Approximate \% Oil in Samples}}$$

For example, if a desludger light phase may have an oil level of about 50% recoverable oil, the sample size is about 0.06 g (= 3 ÷ 50).

4. Determine the sample oil content as in Recoverable Oil of Chapter IV of Procedures for Analysis of Citrus Products.

V. Calculations

The recoverable oil in oil emulsion and oil bearing materials is calculated as following based on 0.0247 N or 0.1000 N potassium bromide-bromate titrant and the fruit oil specific gravity.

$$\begin{aligned} \% \text{ Oil (w/w)} &= \frac{\text{Oil Weight in Sample}}{\text{(g Sample)}} \times 100 \\ &= \frac{\text{(Titrant Volume)Titrant Oil Equivalent)(Oil Specific Gravity)}}{\text{(g Sample)}} \times 100 \\ &= \frac{\text{(Net ml Titrant)(Calculation Factor)}}{\text{(g Sample)}} \end{aligned}$$

Where:

$$\text{(Net Titrant Volume)} = \text{(ml Titrant for Sample)} - \text{(ml Titrant for Blank)}$$

And

Calculation Factor is listed in Table VI – 2C, based on that 1 ml of 0.0247 N KBrO₃-KBr titrant equals 0.0010 ml or 0.00084 of *d*-limonene.

VI. Reference

Official Methods of Analysis. 1999. 16th edition, 5th Reversion, AOAC International, Gaithersburg, MD, method 968.20, 939.12, and 947.13.



Table VI – 2A. Quantity of bulk sample to be collected at different processing points for recoverable oil analysis in oil recovery systems

Processing and Oil Recovery System Stage (common terminology)	Preparation Material Quantity	Note
Extractor Discharges		(JBT citrus extractor)
Juice (raw juice, unfinished juice)	-	Juice stream
Oil slurry	-	Oil recovery system
Peel	2 kg (4 lb)	Cup discharge
Core	2 kg (4 lb)	Orifice tube discharge

From Extractor Discharge: Juice:

Juice Finisher Discharges		(screw or paddle separator)
Juice (pulpy juice)	2 kg (4 lb)	Juice free of peel and membrane
Pulp	2 kg (4 lb)	Solids discharge

From Extractor Discharge: Oil Slurry:

Emulsion Separator Discharges ¹		(screw or paddle separator)
Primary oil emulsion (oil emulsion)	500 ml	Aqueous phase of oil slurry
Peel fragment (Frit)	2 kg (4 lb)	Peel fragments in oil slurry
Secondary Oil Emulsion (Frit wash)	500 ml	Aqueous phase of the wash slurry
Washed Frit	2 kg (4 lb)	Peel fragments in the wash slurry

From Emulsion Separator Discharge: Oil Emulsions:

Desludger Discharges		(first stage centrifuge)
Heavy phase	500 ml	Aqueous phase
Light phase (cream)	100 ml	Oil rich emulsion
Sludge (bowl shoot) ²	2 kg (4 lb)	Solid discharge
Breaker Discharges ³		(second stage centrifuge)
Heavy phase	500 ml	Aqueous phase
Light phase (cream)	100 ml	Oil rich emulsion
Sludge (bowl shoot)	2 kg (4 lb)	Solid discharge
Polisher Discharges		(third stage centrifuge)
Heavy phase	500 ml	Aqueous phase
Light phase (cream)	100 ml	Oil
Sludge ⁴	500 ml	Solid discharge

¹ The primary and secondary oil emulsions can be combined before taking sample for recoverable oil analysis if the distribution in the two emulsions is not of interest. The primary oil emulsion or the combined emulsions also are called desludger feed or weak emulsion.

² For oil recovery system of only two centrifugation stages, there is no second desludger or breaker.

³ When collecting sludge, take sample only during initial discharge that is free of operating water.

⁴ Only if the centrifuge has three outlets.



Table VI – 2B. Preparation of analysis sample for recoverable oil in oil recovery systems

Samples	Quantity	Note
Peel, Core, Frit, or Pulp	500 g	Blend with 3 times weight of cold distilled water (1:3) at low speed for 3 min at ~ 1800 rpm in a 4-liter blender
Juice Oil Emulsion Desludger heavy phase Desludger sludge Breaker heavy phase Breaker sludge Polisher heavy phase	-	Use directly
Desludger light phase	-	Use directly or
Breaker light phase Polisher light phase	5 g	Dilute with 300 ml of isopropanol (235 g) and, while under stirring, slowly add distilled water to 500 g



Table VI – 2C. Calculation factors for recoverable oil in oil recovery systems and available oil in fruit

Fruit	Sample	Dilution Factor	Specific Gravity (g/ml)	Calculation Factor	
				0.0247 N KBrO ₃ -KBr	0.100 N KBrO ₃ -KBr
Orange	Whole fruit	2	0.840	0.168	0.68
	Peel, Core, Frit, Pulp	4		0.336	1.36
	Juice	1		0.084	0.340
	Oil emulsions Desludger/Breaker/Polisher heavy phases and sludges				
	Oil rich emulsion	1		0.084	0.340
Desludger/Breaker/Polisher light phase	100	8.4	34.0		
Grapefruit Lemon Tangerine	Whole fruit	2	0.850	0.170	0.688
	Peel, Core, Frit, Pulp	4		0.340	1.376
	Juice	1		0.085	0.344
	Oil emulsions Desludger/Breaker/Polisher heavy phases and sludges				
	Oil rich emulsion	1		0.085	0.344
Desludger/Breaker/Polisher light phase	100	8.5	34.4		
Lime	Whole fruit	2	0.880	0.176	0.712
	Peel, Core, Frit, Pulp	4		0.352	1.424
	Juice	1		0.088	0.356
	Oil emulsions Desludger/Breaker/Polisher heavy phases and sludges				
	Oil rich emulsion	1		0.088	0.356
Desludger/Breaker/Polisher light phase	100	8.8	35.6		



Table VI – 2D. Target recoverable oil content in citrus oil recovery

Oil Sample	Oil Content (%, w/w)
Oil emulsions	0.5 – 2.5
Desludger/Breaker heavy phases	0.03 – 0.1
Desludger/Breaker sludges	0.1 – 0.5
Desludger/Breaker light phases	25 – 90
Polisher heavy phase	1 - 2
Polisher sludge ¹	2 – 10
Polisher light phase	> 95

¹ Only if the centrifuge has three outlets.



3. Oil-Rich Emulsion Spin Test

I. Apparatus

- Laboratory/clinical centrifuge
- 50ml graduated centrifuge tube with conical bottom

II. Chemicals

None

III. Reagents

None

IV. Procedure

1. Fill a centrifuge tube with 50 ml of oil-rich emulsion sample (i.e., light phases of desludger, breaker, or polisher)
2. Place the tubes in the centrifuge. Make sure load is balanced.
3. Centrifuge for 10 min after reaching a centrifugation force of 365 x g or the speed specified in Table IV-13 based on rotor operation diameter. Once the time required for acceleration is known, combined time can be used at the time of starting the centrifuge.
4. After centrifugation, remove tubes from centrifuge.
5. Determine the bottom water phase volume in milliliters.

V. Calculations

$$\begin{aligned}\text{Approximate \% Oil (v/v)} &= \frac{\text{Volume of Oil}}{\text{Volume of Emulsion}} \times 100 \\ &= \frac{\text{Volume of Emulsion} - \text{Volume of Water Phase}}{50 \text{ ml}} \times 100 \\ &= (50 - \text{ml Water Phase}) \times 2\end{aligned}$$

VI. Reference

Citrus Systems Division, JBT Corporation



4. Total Solids in Oil Emulsion

I. Apparatus

- 25 or 50 ml Buret with 0.1 ml graduation and Teflon® stopcock
- Magnetic stirrer and Teflon® coated stirring bar
- Drying dishes (glass or aluminum foil)
- Analytic balance with sensitivity of 1 mg
- Tongs
- Desiccator and desiccator/Drierite

II. Chemicals

None

III. Reagents

None

IV. Procedure

1. Obtain a representative sample of about 500 ml of an oil emulsion.
2. Weight and label drying dishes.
3. While continuously stirring the sample on a magnetic stirrer, transfer about 6ml into a pre-weighed dish with a disposable pipette.
4. Weigh the dish with sample again.
5. Dry the samples to a constant weight in a drying oven overnight at 93°C (200°F) or 4 to 6 hours in a vacuum drying oven at 70°C (185°F) and 25 mmHg (3.3kPa).
6. Weigh sample after transferring dishes using a pair of tongs from the oven into a desiccator to cool.

V. Calculations

$$\% \text{Total Solid (w/w)} = \frac{(\text{weight of Dried Sample and Dish}) - (\text{Weight of Dish})}{(\text{Weight of Wet Sample and Dish}) - (\text{Weight of Dish})} \times 100$$

VI. Reference

Citrus Systems Division, JBT Corporation



5. Recoverable Oil (Scott Method)

I. Apparatus

- Electric heater with recessed refractory top, 500 – 700 watts.
- Still with 500 ml flat-bottom distillation flask with 24/40 neck; 200 mm Graham
- Condenser with 28/15 receiving socket and drip tip; connecting bulb (Iowa state type 90 x 35 O.D.) 4
- Hot glove or pad
- Magnetic stirrer and Teflon® coated stirring bar
- 10 ml Buret with 0.1 ml division

II. Chemicals

- Potassium bromide (KBr)
- Potassium bromate (KBrO₃)
- Isopropanol (C₃H₈O)
- Arsenious oxide (As₂O₃)
- Sulfuric Acid (H₂SO₄)
- Methyl Orange (C₁₄H₁₄N₃O₃SNa)
- Hydrochloric acid (HCl)

III. Reagents

Potassium bromide-bromate solution (PBB, ~0.1 N): Dissolve 2.8 g of KBrO₃ and 12 g of KBr in distilled water and make up to 1000 ml.

To standardize the PBB solution, titrate it with a mixture of 40 ml standard As₂O₃ solution and 10 ml diluted HCl solution (1:3, v/v with distilled water) with 3 drops of methyl orange based on the formula:

$$\begin{aligned}\text{Normality of PBB} &= \frac{(\text{ml As}_2\text{O}_3)(\text{N As}_2\text{O}_3)}{(\text{ml PPB})} \\ &= \frac{(40 \text{ ml})(0.1 \text{ N})}{(\text{ml PPB})} \\ &= \frac{4}{(\text{ml PPB})}\end{aligned}$$



Based on the actual normality of the PBB stock solution, make proper dilution with distilled water to obtain 0.0247 N solution for titration.

$$\text{PBB (ml to make 1,000 ml 0.0247 N Solution)} = \frac{(0.0247 \text{ N})(1,000 \text{ ml})}{(\text{N PPB})}$$

Arsenious oxide standard (0.100 N) is prepared as: Dry ~6 g of As_2O_3 for 1 h at 105°C (221°F), immediately accurately weigh 4.950 g and dissolve in 1 N NaOH (50 ml/5 g As_2O_3) in flask or beaker by heating on a steam bath, add the same volume of 1N H_2SO_4 to neutralize the solution, and transfer to a 1,000ml volumetric flask, rinse the beaker repeatedly with distilled water to assure complete transfer and then make up to the 1 liter mark.

Methyl orange solution (0.1%): Dissolve 0.1 g of methyl orange in 100 ml distilled water.

Dye solution: In a fume hood or a well ventilated area, slowly add 1 part of HCl to 2 parts of distilled water. Then add 5 ml of 0.1% methyl orange solution and mix well.

IV. Procedure

1. To a 500-ml distillation flask, add 25 ml of isopropanol, 25 ml of sample.
2. Turn on the heater and run cold water through the condenser from bottom to top.
3. Place a 150-ml beaker under the condenser flow out.
4. Attach the flask to the connecting trap of the condenser and rest on the turned-on heater.
5. Wait for distillation completion that is indicated by water condensation inside the connecting tubes or stop of solvent reflux. Time is about 3 to 3.5 min and distillate volume exceeds 30 ml.
6. Add 10 ml of the dye solution into the beaker.
7. Titrate the distillate in the beaker with the 0.0247 N $\text{KBr}_3\text{-KBr}$ solution to the disappearance of the dye color.
8. Record the amount of titrant used.
9. Determine reagent blank by titrating 3 mixtures of 25ml of isopropanol and 10 ml of dye-HCl solution without refilling the buret. Divide total titrant volume used by 3 to get the average blank value.



V. Calculations

Since 1 mole of d-limonene reacts with 2 moles of Br₂ or 4 moles of Br (bromine), 1ml of 0.0247 N KBrO₃-KBr titrant equals 0.001 ml or 0.00084 g of d-limonene and equals 0.004% oil by volume for 25-ml sample

$$\begin{aligned} \% \text{Oil (v/v)} &= \frac{\text{Volume of Oil in Sample}}{\text{Volume of Sample}} \times 100 \\ &= \frac{(\text{ml Titrant})(\text{N Titrant})(1/4)(\text{MW of Limonene})(\frac{1}{\text{Oil Specific Gravity, g/l}})}{(1,000 \text{ ml/l})(\text{Volume of Sample})} \times 100 \\ &= \frac{(\text{ml Titrant})(0.0247 \text{ N})(1/4)(136.23 \text{ g/mole})(\frac{1}{0.84 \text{ g/ml}})}{(1,000 \text{ ml/l})(\text{ml Sample})} \times 100 \\ &= \frac{(\text{ml Titrant})(0.00084 \text{ g (1/0.84 g/ml)})}{(\text{ml Sample})} \times 100 \\ &= \frac{(\text{ml Titrant})(0.0010 \text{ ml})}{(\text{ml Sample})} \times 100 \\ &= \frac{(\text{ml Titrant})}{(\text{ml Sample})} \times 0.1 \end{aligned}$$

Where:

$$(\text{Net ml KBrO}_3\text{-KBr}) = (\text{ml KBrO}_3\text{-KBr for Sample} - \text{ml KBrO}_3\text{-KBr for Blank})$$

For 25 ml juice sample titrated with 0.0247 N KBrO₃-KBr

$$\begin{aligned} \text{Oil (v/v)} &= \frac{(\text{Net ml KBrO}_3\text{-KBr})(0.0010 \text{ ml})}{(25\text{ml})} \times 100 \\ &= (\text{Net ml KBrO}_3\text{-KBr}) \times 0.004 \end{aligned}$$

VI. Reference

Official Methods of Analysis. 1999. 16th edition, 5th Reversion, AOAC International, Gaithersburg, MD, method 968.20, 939.12, and 947.13.
Scott, W.C. and M.K. Veldhuis. 1966. Rapid stimulation of recoverable oil in citrus juices by bromate tritration. J. AOAC. 49:628-633.



6. Orange Cold Pressed Oil Testing

In Feed to Desludger

1. Weigh 1 gram of sample, add 25 ml isopropanol, add 25 ml distilled water
2. Distill and titrate using Scott Oil Method
3. Calculate: $\frac{(\text{mls titrant})(0.001 \text{ ml d'limonene/ml})(0.84)}{1 \text{ gram}} \times 100 = \% \text{ oil w/w}$

EASY CALCULATION: (mls used in buret) x (0.084) = % oil w/w

Water Discharge from Desludger and Desludger Sludge

1. Weigh 5 grams of sample, add 25 ml isopropanol, add 25 ml distilled water
2. Distill and titrate using Scott Oil Method
3. Calculate: $\frac{(\text{mls titrant})(0.001 \text{ ml d'limonene/ml})(0.84)}{5 \text{ grams}} \times 100 = \% \text{ oil w/w}$

EASY CALCULATION: (mls used in buret) x (0.0168) = % oil w/w

Cream, or Oil Rich Emulsion from Desludger & Polisher Sludge Discharge

1. Weigh 10 gram of sample, add distilled water to get 1,000 grams
2. While stirring, remove and weigh 5 grams of above solution, add 25 ml isopropanol, add 25 ml distilled water
3. Distill and titrate using Scott Oil Method
4. Calculate: $\frac{(\text{mls titrant})(0.001 \text{ ml d'limonene/ml})(0.84)}{0.05 \text{ gram}} \times 100 = \% \text{ oil w/w}$

EASY CALCULATION: (mls used in buret) x (1.68) = % oil w/w

* 0.025 N Potassium Bromide Bromate solution to be used as titrant

** % Efficiency = In-Out/In x 100



7. Grapefruit Cold Pressed Oil Testing

In Feed to Deslugger

1. Weigh 1 grams of sample, add 25 ml isopropanol, add 25 ml distilled water
2. Distill and titrate using Scott Oil Method
3. Calculate: $\frac{(\text{mls titrant})(0.001 \text{ ml d'limonene/ml})(0.85)}{1 \text{ gram}} \times 100 = \% \text{ oil w/w}$

EASY CALCULATION: (mls used in buret) x (0.085) = % oil w/w

Water Discharge from Deslugger and Deslugger Sludge

1. Weigh 5 grams of sample, add 25 ml isopropanol, add 25 ml distilled water
2. Distill and titrate using Scott Oil Method
3. Calculate: $\frac{(\text{mls titrant})(0.001 \text{ ml d'limonene/ml})(0.85)}{5 \text{ grams}} \times 100 = \% \text{ oil w/w}$

EASY CALCULATION: (mls used in buret) x (0.017) = % oil w/w

Cream, or Oil Rich Emulsion from Deslugger & Polisher Sludge Discharge

1. Weigh 10 gram of sample, add distilled water to get 1,000 grams
2. While stirring, remove and weigh 5 grams of above solution, add 25 ml isopropanol, add 25 ml distilled water
3. Distill and titrate using Scott Oil Method
4. Calculate: $\frac{(\text{mls titrant})(0.001 \text{ ml d'limonene/ml})(0.85)}{0.05 \text{ gram}} \times 100 = \% \text{ oil w/w}$

EASY CALCULATION: (mls used in buret) x (1.70) = % oil w/w

* 0.025 N Potassium Bromide Bromate solution to be used as titrant

** % Efficiency = $\frac{\text{In-Out}}{\text{In}} \times 100$



13. Troubleshooting Guidelines

1. Frequently plugged spray rings on the extractors are an indication of a problem with the recycle water filters. Check for filter at the extractor and in-line filters.
2. A frequent and erratic change in the volume of water flowing to the extractors indicates too long of a backwash cycle time on the water filter system.
3. If “mud” is being discharged from the desludger centrifuge:
 - a) Check the water “blowdown” valve for the correct setting or decant settings. The water going to the extractors should not contain less than 20% fresh water.
 - b) Look for air leak sources in the centrifuge feed piping. If air leaks occur, they will usually be located on the suction side of the desludger feed pump.
 - c) An internal desludger gasket may have failed, allowing excess air into the emulsion. This can only be fixed by shutting down the system and disassembling the centrifuge for a careful inspection.
 - d) Check the back pressure valve adjustments. Some backpressure is required on the heavy phase discharge (recycle water) or on the oil-rich phase discharge of a centrifuge to force the oil and water to separate properly in the centrifuge. This will vary from machine to machine and from installation to installation. Careful operating records should be kept for each machine so all operators can operate them the same way.
 - e) Check to see that the frit finisher is not grinding excessively, increasing the insoluble particle and consequently increasing the oil emulsion viscosity. Also, frequently check the condition of the finisher screens to assure that no large holes or tears have occurred.

WARNING: Do not check finisher screens by hand while finisher is running. Serious injuries can occur.

- f) Assure that desludger feed tank is not operating at too low of an operating level, sending excess air and “frothy” material to the centrifuge. The frothy material will not separate out of the feed emulsion in a centrifuge and will contaminate the cream.
- g) Check the pH of the feed emulsion to assure that no incidental caustic contamination has occurred, 7 pH or below.
- h) Assure that the oil content in the feed emulsion has not dropped below 0.7%. Adjust the water flow to the extractors to maintain at least 1.0% oil content in the feed emulsion.
- i) Check if the emulsion viscosity is below 6 cPs. If the emulsion viscosity is above 6 cPs, adjust the recycle water decant tank to skim more water and add fresh water to reduce the viscosity.



- j) Check the oil concentration of the cream; it might be too low. The optimal range is from 65-85% oil.
 - k) Verify how long the de-sludger centrifuge has been running since the last clean-up. After 12 hours of operation, the de-sludger centrifuge presents a big drop in efficiency due to the wax and particle that remain on the discs.
 - l) Check the amount of sludge shot by the de-sludger centrifuge. A small shoot will reduce the centrifuge efficiency and will block the recycle water path, sending more water to the oil-rich emulsion discharge.
4. If overall oil recovery efficiency drops below normal:
- a) Check the water flow to the extractors. Check that the feed emulsion viscosity is below 6 cPs. Adjust the water flow to the extractor to reduce the emulsion viscosity and add more fresh water in the process.
 - b) Assure that the volume of recycle water being used is not too great. Using more than 80% recycle water to recover oil at the extractors will increase the recycle water viscosity.
 - c) Check that the water filters are properly removing peel solids from the water.
 - d) Verify if the polisher centrifuge is not shooting free oil in the sludge. Adjust the oil-rich emulsion flow to avoid free oil in the sludge reducing it.
 - e) Verify the last time that the de-sludger centrifuge was cleaned.
The de-sludge centrifuges must be cleaned at least every 12 operation hours.



14. Maintenance Guidelines

The following guidelines are general in nature and should be modified for each particular oil recovery system based upon experience.

Centrifuge Inspection

1. Break down centrifuges at least once per year and inspect and replace internal gaskets and seals. Some of the seals can be reused after inspection if they are in good condition, replace if there are wear marks or other signs of deterioration.
2. Internal leakage, when it occurs, is usually from a bad bowl gasket. If not fixed when they occur, the lip of the sliding piston can be cut, necessitating more expensive repairs.
3. Carefully inspect the interior rotating parts for damage and sand erosion, and if noted be sure to follow the proper repair procedures in the centrifuge operating manual. Enlist the help of a qualified centrifuge repair expert if any doubt exists as to the correct repair procedures.
4. Upon reassembling a centrifuge, start it up following the procedures in the centrifuge operating manual and carefully observe that no abnormal vibration is occurring as it gains speed. If any vibration is observed, immediately shut off the power to the drive motor and allow the centrifuge to stop rotating. If equipped, use the built-in bowl brakes to stop the bowl rotation as quickly as possible. Do not, under any circumstances, restart the centrifuge until a thorough inspection is undertaken that reveals the cause of the vibration and appropriate repairs are made. Excessive vibration can cause a centrifuge to self-destruct with possible disastrous consequences to both property and people.
5. Where it is appropriate to the model of the centrifuge in use, be sure to inspect the lubricating oil for water and metallic wear particles daily.