



## Case Packing Machinery

Proseal's Case Packing machinery range provides the ideal complement to Proseal tray sealing machinery

Our philosophy is to complete the modern high-speed packing line with a solution that is cost effective, efficient and delivers exceptional performance within a compact footprint.

Capable of over 200\* packs per minute, the **Proseal Case Packing** range utilises the latest 2D delta robotic system, which boasts unrivalled flexibility and is adaptable for different tray sizes, configurations and loading formats.

A key feature of this system is the quick-release tooling that significantly reduces product changeover times, which along with an intuitive recipe-based control system, allows product changeovers to be completed in less than a minute.

At the core of the design is our tried and tested **ProMotion™** intelligent, non-stop, tray spacing system. With millions of miles now on the clock in production environments, it is an obvious technology to utilise for this crucial part of the packaging process. Allied to this efficiency principle is the common use of Proseal spare parts, shared across our tray sealing and case packaging range, and other industry leading Proseal features.

With a number of options within the range, the **Proseal Case Packing** machines are capable of packaging any format, including non-tray sealed packaging, from low volume right through to ultra-high-volume production.

\*Subject to machine variant/tooling configuration

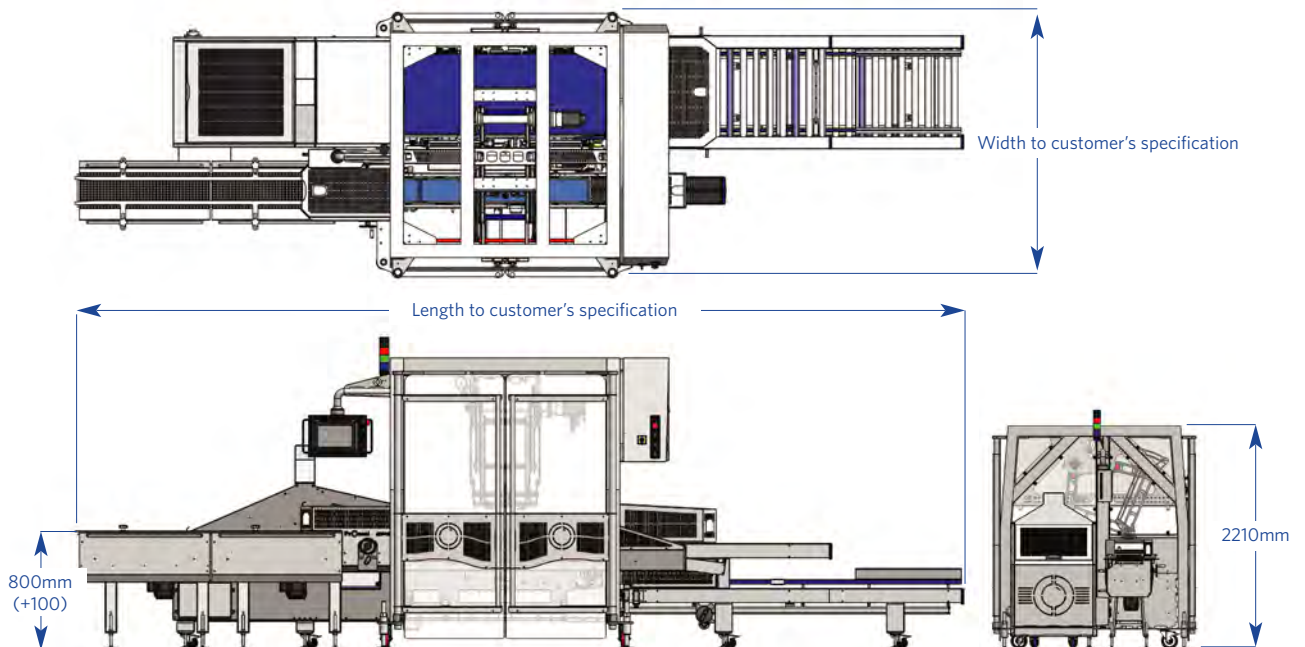

## Standard design features and benefits

- **ProMotion™** - a high accuracy continuous motion tray infeed system, which increases production speed whilst reducing machine duty
- **ProTect™** - a contactless machine login and audit trail system
- **ProVision™** compatibility
- 1-2m Soft touch tray buffering conveyor
- Automatic filled crate discharge
- Auto tool technology for pack format changes
- 100m<sup>3</sup> per hour vacuum pump supplied as standard
- User friendly, menu-driven control panel with step-by-step prompts, error and status displays, and useful batch pack counter
- Recipe driven auto machine set-up for tool change
- On-screen data capture and trends with wireless connection option
- **QRconveyors™** with quick release belts for easy hygiene and maintenance
- 2 Axis delta robotic operation
- Self-centering guides
- Compatible with modern board materials

## Options available

- Pack orientating conveyor
- Bespoke crate delivery and discharge conveyors to fit into your complete factory layout
- Increased length of buffering conveyor for higher speeds
- Additional crates fill for higher speeds
- Integration of peripheral equipment, such as: case erectors, existing crate delivery system, labellers and coders
- Multiple quick change end effector options
- **AutoCoding Ready**
- Transformers available to suit most electrical supply voltages used worldwide
- Sale, Lease Purchase and Rental options available



## CP Specifications

Height	2210mm
Standard Length	length to customer's specification
Width	width to customer's specification
Weight	specification dependant
Electrical Supply	415V 3 phase + neutral (fused at 16A)

Transformers are available to accommodate the electrical supplies in different countries

## Metric

## Imperial

Pressure	Flow	Pressure	Flow
6 Bar	226L/Min	87psi	8CFM



PROTEIN



DESSERTS



SANDWICHES



BEVERAGE



SOFT FRUIT

for more information **UK** +44 (0) 1625 856 600 **America** +1 804 447 9038 **Australia** +61 (0) 3 9397 1488

[www.proseal.com](http://www.proseal.com)