



New SeamTec™ for Powder

Designed for packing
high value powders

Metal or composite double-seamed cans, lithographed or labelled, are frequently used for packing high value, premium powders. Food processors select the can to pack their premium brands of infant formula, milk powder, instant coffee, chocolate or sports drinks powder.

The metal or composite cans can be fitted with a peelable, easy-open lid, typically covered with a plastic cap for re-closability. Cans offer the consumer a high level of product quality, safety and convenience. Lithographed metal cans strengthen the consumer's perception of the product as being safe and of the highest quality.

JBT's SeamTec™ for Powder addresses the need for closing of round cans in a hygienic and easy-to-clean environment. SeamTec™ for Powder delivers a consistent, high-quality seam and can appearance at the lowest cost per unit produced.



The powder seaming challenge



Processors of powders, in particular infant formula powders, place the highest demands on hygienic design and cleanability of their clinching and closing equipment. It is essential that the closed can and product contained inside are of impeccable quality. Since multiple can formats are typically run on a single line, quick can format change-over, without the need for the intervention of a seaming expert, is a requirement.

JBT's new SeamTec™ for Powder is a breath of fresh air in the world of closing powder cans. Over the last 10 years JBT has focused on creating a machine designed especially for this purpose. When developing the SeamTec™ for Powder, special care was taken to ensure that every new feature incorporated enhanced hygiene and cleanability, quick and easy change-over as well as gentle, zero-defect can handling.

JBT's innovative rotary seaming technology stands out from conventional can closers by unique properties. This white paper introduces you to the unique features of the new SeamTec™ for Powder.

Concerned product applications:



Infant Formula



Milk Powder



Instant Coffee

Chocolate Drink Powder



Sports Drink Powder



Other food products packed in composite cans



In order to meet a JBT seaming expert to have a closer look at your specific product requirements, simply e-mail us on hello@jbt.com



Filling all the expectations of powder processors

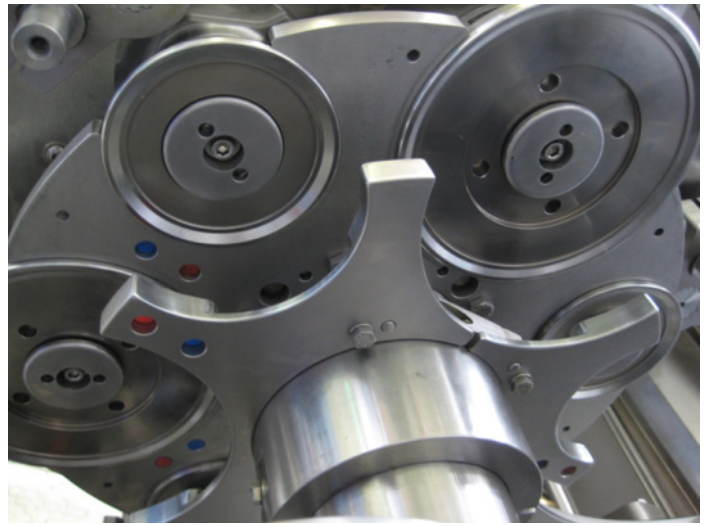
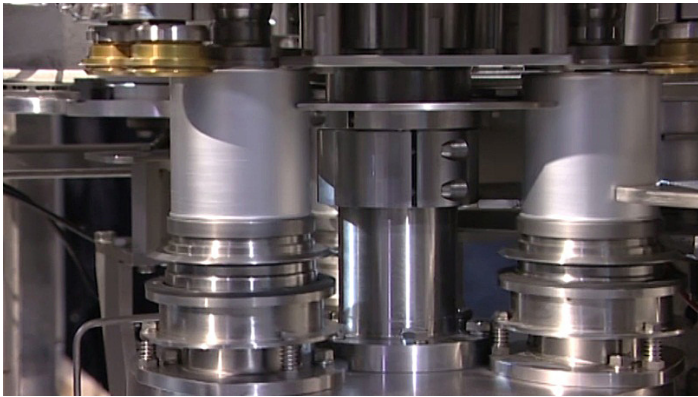

▲ SeamTec™ for Powder Combi

SeamTec™ for Powder - technology was developed and tailored to several of JBT's powder customers in a period of now about 10 years. The seamer was thoroughly tested in production and adjusted in order to guarantee the highest product quality at the lowest cost per unit produced.

A well thought range of seamers was put together to ensure that the new SeamTec™ for Powder could be fitted perfectly into the existing can production line.

JBT's unique 6-head design is a state-of-the-art seamer that can run up to Ø127 cans on all 6 seaming heads at speeds up to 450 cans/minute (27,000 cph).

The combi variant of the ST206 is fitted with a seaming head pre-set for 2 can diameters. As a result no change-over is required for the essential machine parts. A unique feature truly dedicated to powder applications that doesn't need a seamer specialist and reduces machine downtime.

SeamTec™ for Powder Machine Range

Model	Seaming Stations	Can Diam Range	Speed Range
ST203	3	99 - 154 mm (401 - 603)	Up to 300
ST206	6	99 - 127 mm (401 - 502)	Up to 600
ST206 COMBI	3 + 3	99 - 154 mm (401 - 603)	Up to 300



SeamTec™ for Powder Configurations

JBT's SeamTec™ for Powder comes in several possible configurations in order to fully meet each can packaging principle, pre- or post gassing requirements:

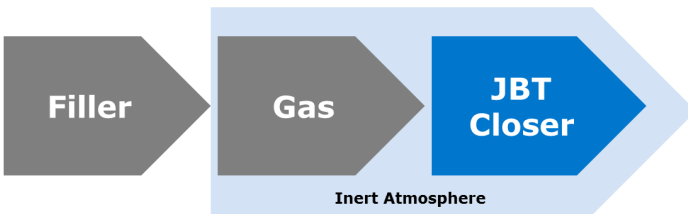
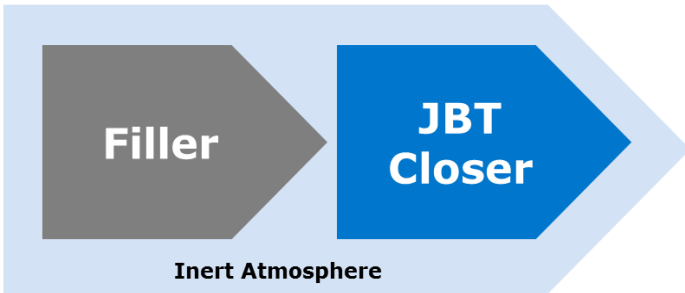

▲ JBT SeamTec™ Pre-gassing Closer with gas-tight guarding



▲ JBT SeamTec™ Clincher
▼ JBT SeamTec™ Closer (after clincher)

Top rail gassing with a JBT closer using laminar flow ▼



Unmatched Powder Seaming Technology



The SeamTec™ for Powder is designed with a completely closed oil-lubricated seaming head and lifter table. ▲

High-tec seaming head

The new JBT SeamTec™ for Powder is equipped with a high-tec seaming head. The seaming station and lifters are oil lubricated for sustainable and carefree operation. The spindles, lifters construction and the short and robust seaming arms have been specially designed for heavy duty and long life. The return of the can ejector pad and the single seaming arm – for 1st and 2nd seaming operations – are mechanical forced and not spring activated. This allows high operating speed with consistent seaming quality.



Adjustable cover feeding

The SeamTec™ for Powder is equipped with an oil-lubricated triple screw cover feeding system. It automatically detects reversed covers which can easily be removed during operation. Furthermore, a continuous cover stack pressure control guarantees an ever consistent and gentle cover feed.





Gentle can in-feed

The SeamTec™ for Powder guarantees a gentle can in-feed. A synchronized can stop turret and infeed scroll (1) avoids denting. Powder spillage at a line stop is prevented by a can stop turret made of a flexible synthetic material (2). The hard-chromed change parts avoid scratches on lithographed cans.

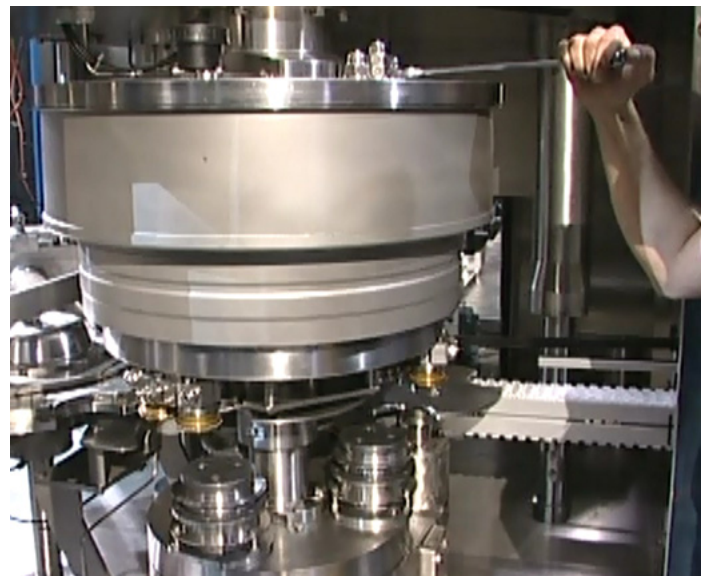
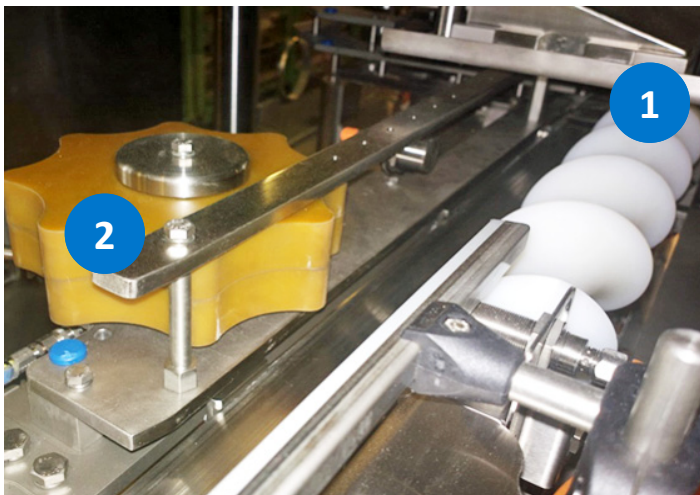

Easy seam setting

Another interesting feature of the SeamTec™ for Powder is the easy seam setting. When your engineers want to verify the quality of the seam, they do not have to dismantle the second operation seaming rolls to run a test of the first seaming operation. To avoid excessive downtime, they can easily disengage the second seaming operation and focus on the first which is crucial for seam quality.

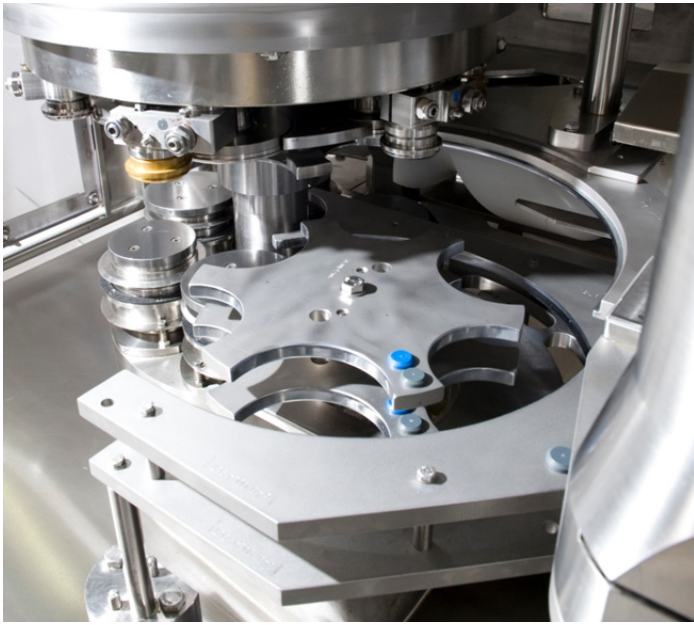

▲ All change parts are colour-marked and match the HMI. The change-over downtime is minimized by automatic height adjustment and locating pins for easy installation of the change parts.

Quick can & cover format change-over

A highly important operational benefit of the SeamTec™ for Powder is a quick can and cover format change-over.

There is no need to change the separate rolls. The lower seaming arm can be changed quickly without disassembly and easily positioned with a spline and a locating pin. The same goes for the can and cover handling parts. An optional motorized can height adjustment will further increase machine uptime.



Superior hygienic design

Recalls due to possible contamination are an absolute disaster for processors of high value powders. Therefore JBT has always considered food safety as an absolute top priority. Based on customer input, the SeamTec™ for Powder has been designed in keeping with the highest sanitary demands (e.g. EHEDG and 5S).

Its superior hygienic qualities are achieved by avoiding powder spillage, not exposing lubricants and an overall easy-to-clean design.



No powder spillage

No powder spillage during the seaming process is an uppermost critical-to-quality attribute. The SeamTec™ for Powder avoids powder bridging through the seam and spillage of the open can.

The stopping lifters of the SeamTec™ for Powder make sure that the cans do not rotate when still open. Rotation only begins once the cover is pressed on the can.

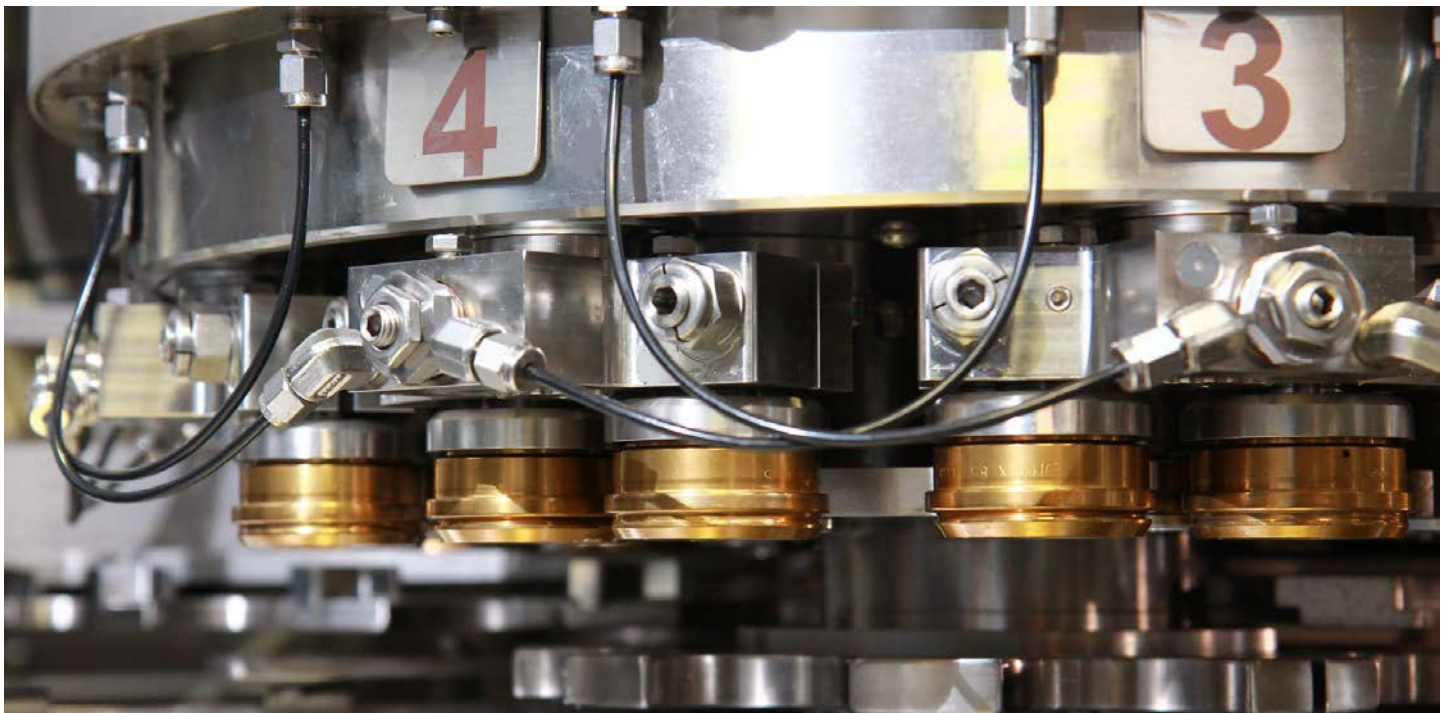

Not exposing lubricants

The SeamTec™ for Powder is designed with a completely closed oil lubrication system for the seaming head and lifter table. This system captures the currently used oil, filters it and sends it back to the seaming head and lifter table.

The seaming rolls, on the other hand, are automatically lubricated in perfect doses by unexposed greasing nozzles.

The Seamtec™ for Powder transfers the can all the way to the lifter by an infeed scroll instead of an infeed chain. The absence of an infeed chain means there is no need for lubrication, as well as fewer change and wear parts.

Hygienic guarding

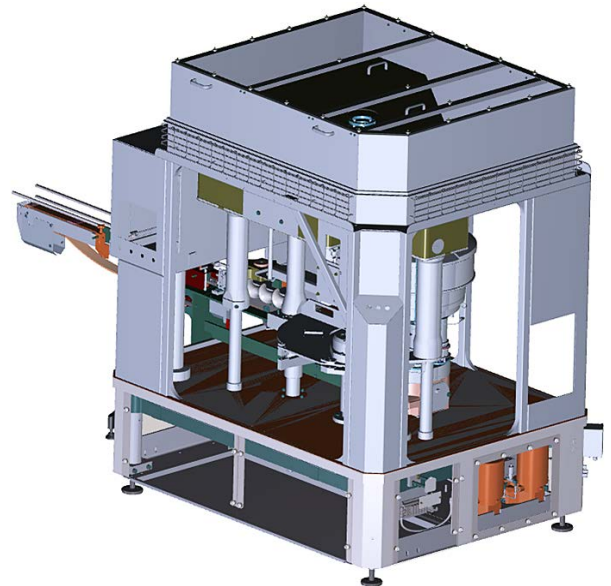

The key inspection points have been made as visible as possible by transparent upper and lower guarding and optional LED-lighting. These features allow a high level of inspection.

The upper and lower guarding is equipped with large access doors facilitating thorough and easy vacuum cleaning. The main parts received a ViwateQ stainless steel surface treatment to reduce adhesion of powder on the main parts. The design of the guarding also significantly reduces hollow bodies and dead crevices, provides single layer cable ducting and minimizes fasteners.

In short: well-thought-out features for enhanced hygiene in an easy to clean environment.

▼ Scroll in-feed without exposed lubricants



State-of-the-art performance at the lowest TCO

(Total Cost of Ownership)



When developing the seamer, JBT's engineers paid particular attention to lean production values: maximum value for the customer with the lowest possible product waste and operating costs.

The transparent guarding and LED-lighting allow the operator to carry out quick inspections to verify the seamer is functioning properly. If necessary, they can make swift interventions through the large access doors.

Change-overs will therefore require less time and will be largely pre-programmed via the console.

Machine lubrication is mostly automated. Main drive parts and seaming rolls are automatically grease lubricated. Seaming head and lifter table are automatically oil lubricated. Under the base plate of the seamer an oil recuperation and filtration system is provided.

Dust explosion safety

It is JBT's responsibility (machinery directive 2006/42/EC) to design and manufacture safe machinery to avoid risk of explosion posed by the machinery itself or by other substances (gases, liquids, dust, vapour, etc.) produced or used by the machinery.

The SeamTec™ for Powder can come in a dust explosion safe version based on your powder specifications and on-site ATEX regulations.

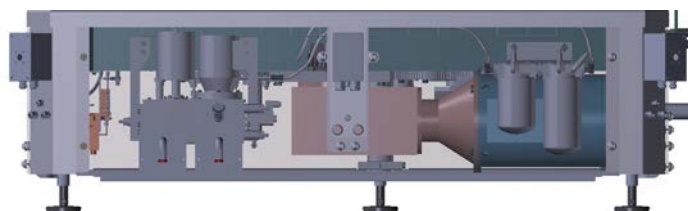
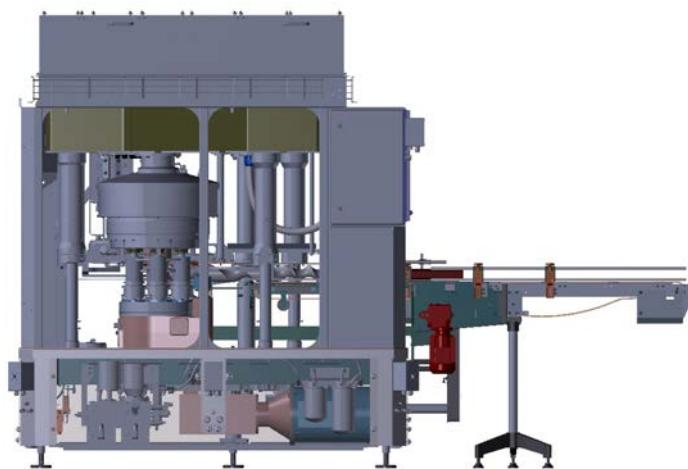
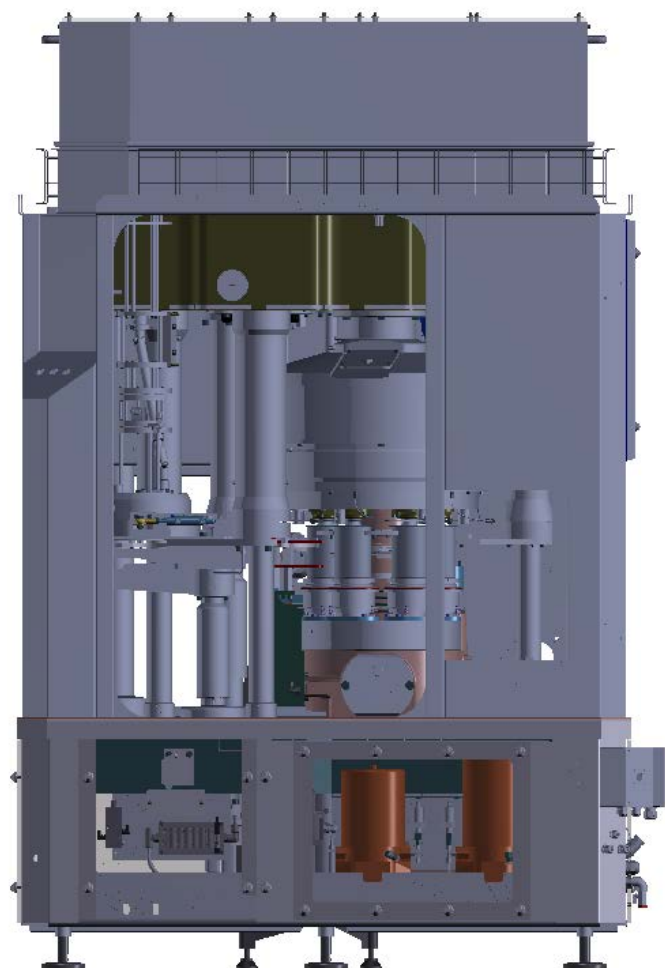

This white paper is also available in
a French and German version on
www.jbtcorporation.com



Food processing expertise at your service, around the globe

Our mission: providing you with maximum uptime and smooth operation. Therefore, you can count on JBT for technological support, installation supervision, training and after-sales support anywhere in the world.

JBT has a long history of food processing equipment. Having sold over 40,000 machines worldwide our service technicians have faced and solved some of the toughest problems for processors within the food industry. JBT offers OEM parts for repairs and maintenance. Over 6,000 parts can be shipped within 24 hours to all continents. Other examples of JBT customer service include the standard exchange assemblies and preassembled kit to reduce downtime due to maintenance and repair. Our range of service packages make sure your equipment keeps running as profitably as possible, for as long as possible. With minimum downtime.

More than 50% of the world's shelf-stable foods are filled, seamed or sterilized on JBT equipment. With several thousands of canning lines in operation worldwide, JBT is the world's leading supplier of integrated processing solutions for metal, glass and plastic containers. From single machines to complete processing lines, we enhance product value and safety. JBT equipment captures the quality, nutrition and taste of your product at the lowest cost per unit produced.



Europe

John Bean Technologies N.V.
Breedstraat 3
9100 Sint-Niklaas | Belgium

Tel: +32 3-780.1211
Fax: +32 3-777.7955
fpsd.info@jbtc.com

JBT Netherlands B.V.
Gyroscoopweg 84-1
1042 AX Amsterdam | The Netherlands

Tel: +31 20-723.4700
Fax: +31 20-411.8273

John Bean Technologies S.p.a.
Via Mantova 63 A
43122 Parma | Italy

Tel: +39-0521-908.411
Fax: +39 0521-460.897
sales.parma@jbtc.com

North America

John Bean Technologies Corporation
2300 Industrial Avenue
Madera CA 93639 | USA

Tel: +1-559-661.3200
Fax: +1-559-661.3156
madera.fpsd@jbtc.com

Latin America

John Bean Technologies Ind.e.Com Ltda.
Av. Eng. Camilo Dinucci, 4605
II Distrito Industrial
14808-900 Araruama SP | Brazil

Tel: +55-16 3301 2000
Fax: +55-16 3301 2155
latinamerica.info@jbtc.com

Asia Pacific

John Bean Technologies Thailand Ltd.
159/26 Serm-Mit Tower, Room no. 1602-3
Sukhumvit 21 Road
Klongtoey Nua Sub-district, Wattana District
Bangkok 10110 | Thailand

Tel: +66-2257.4000
Fax: +66-2261.4099
infoasia-jbtfoodtech@jbtc.com

