



**STRONGER  
TOGETHER**

**PRIME  
EQUIPMENT GROUP**  
*Simple Solutions for Poultry Processing*

## POSITIVE-FEED NECK SKINNER

Model No. PFNS-1

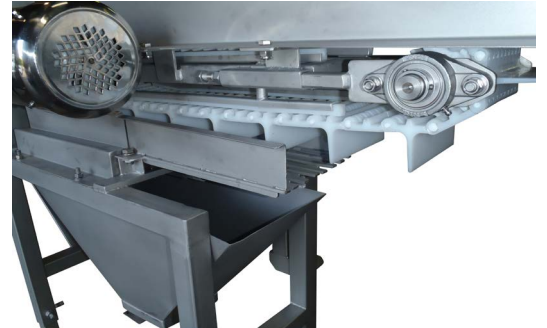

The PFNS-1 Positive-Feed Neck Skinner is a safe and efficient solution for removing the skin from detached chicken necks. This gives poultry processors the ability to maximize their neck processing efficiencies without sacrificing product quality. Combine the PFNS-1 with the WLNSC-1 Wing Lift Neck Skin Cutter for a fully automated neck processing system.

TWO SETS OF ROTATING PEELER  
ROLLERS SKIN DETACHED NECKS  
PEELER CONFIGURATION REDUCES  
YIELD LOSS FROM ENDS OF NECKS  
INDEXING BELT MINIMIZES PRODUCT  
DAMAGE AND LOSS

See Prime in action: View  
[www.PrimeEquipmentGroup.com/videos](http://www.PrimeEquipmentGroup.com/videos)

Viewing online?  
Click here

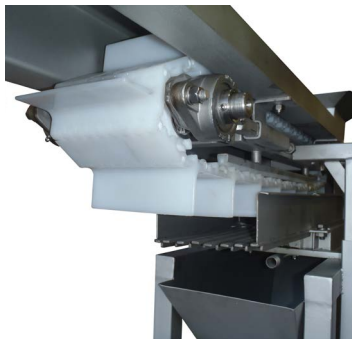

### PRIME ROI:

REQUIRES NO LOADER; OPERATES UP TO 200 BPM  
COMBINE WITH PRIME'S WING LIFT NECK SKIN CUTTER FOR  
A FULLY AUTOMATED NECK-PROCESSING SYSTEM



2001 Courtright Road  
Columbus, OH 43232 USA



Please call  
**+1 (614) 253-8590**



Send us an email  
[Sales@PrimeEquipmentGroup.com](mailto:Sales@PrimeEquipmentGroup.com)



More info  
[PrimeEquipmentGroup.com](http://PrimeEquipmentGroup.com)



**STRONGER  
TOGETHER**

**PRIME  
EQUIPMENT GROUP**  
Simple Solutions for Poultry Processing

# POSITIVE-FEED NECK SKINNER

Model No. PFNS-1

## Positive-Feed Neck Skinner

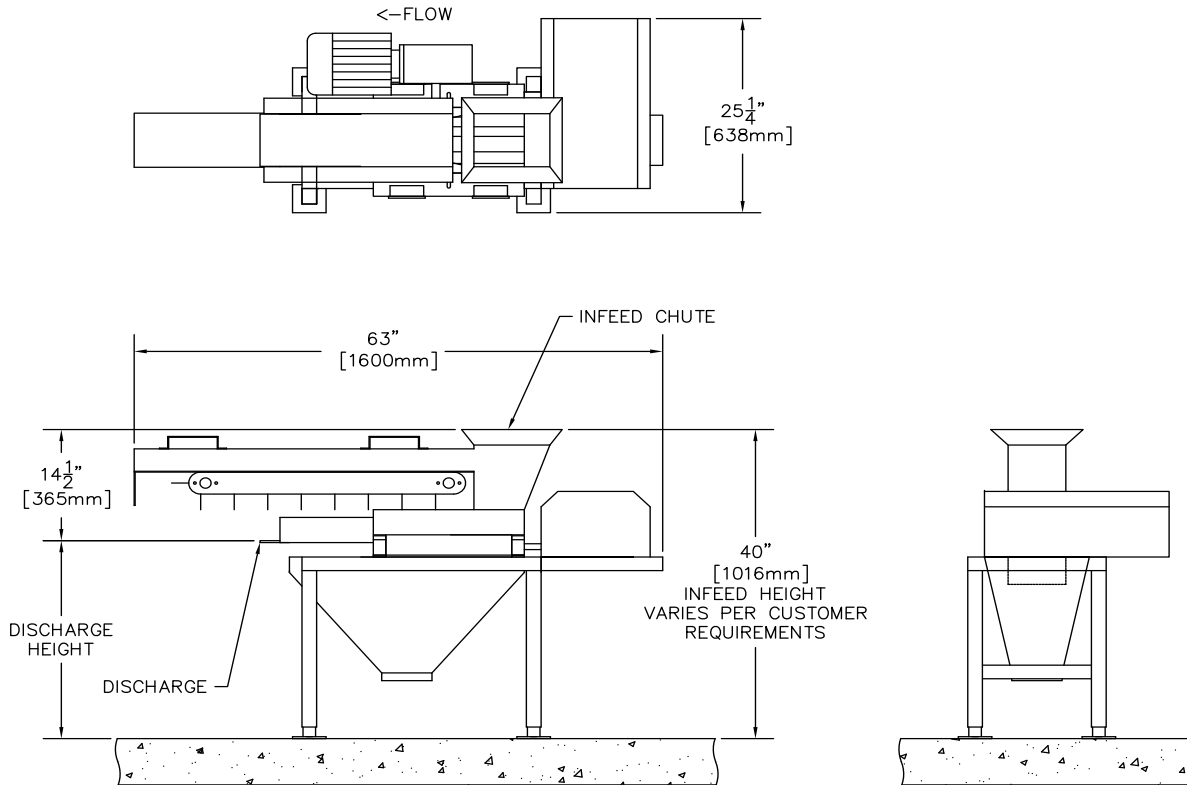

### TECHNICAL SPECIFICATIONS

Electrical Requirements:	230/460V, 3 ph (others available)
Motor Specifications:	(1) 2 hp motor, (1) 1/2 hp motor
Water Requirements:	(1) 3/4" NPT connection; 10 GPM
Net Weight:	Approx. 400 lbs. (181 kg)
Production Rate:	Up to 140
NOTE: Specifications are accurate at time of publication	