

**SuperCRss™**



The JBT Mild Steel SuperCRss™ Retort:  
Field-proven Sterilization Technology with  
Robust Automation Solutions



## A fully automated retort that processes cans of all sizes and volumes from large foodservice cans to small retail cans.

The SuperCRss sterilizes foods such as beans, fruits, vegetables, meat, soups and pet food. This retort equipped with a LOGTEC Process Controller and coupled to an automatic loading & unloading system provides the customer with food safety, basket tracking, equipment reliability and labor savings.

### Retort Technical Details:

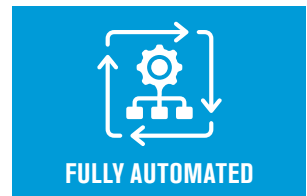

### Available Options

- ✓ Fully automated or manually operated
- ✓ Integrated with Material Handling System
- ✓ Holding capacity from 6 to 12 baskets
- ✓ Global Pressure Vessel Certification
- ✓ LOG-TEC Momentum or Model E Control Platform
- ✓ Industry 4.0 with iOPS
- ✓ Double Door
- ✓ Internal Conveyor



### Features and Benefits

- Mild Steel:** Long Life\*
- Saturated Steam Cook:** Superior heat transfer to product
- Direct Cool:** No pumps or heat exchangers
- Static Processing:** No damage to sensitive products
- Flexibility:** All rigid container sizes and shapes
- Up to 12 Basket Capacity:** High throughput
- Automated Conveyor and Doors:** Personnel safety and reduced labor
- Fully Automated:** Reduced labor and high efficiency
- LOG-TEC Process Controller:** Food Safety, FDA CFR21.11 Compliant
- Insulated Shell:** Reduced Steam Consumption
- Clog Resistant Nozzles:** Reduced maintenance

\* Long life thanks to the use of mild steel that enables direct cooling without the possibility of stress corrosion cracking.



## Automated Batch Retort Systems (ABRS)

ABRS refers to the fully automated integration of all the equipment needed to load, transport and sterilize, and then unload canned products, providing a steady stream of containers into and out of the system. JBT offers a complete and proven turn-key installation of an automated batch retort system.

### Loading & Unloading Systems

Our basket loading/unloading technology works with rigid containers such as metal cans or with tray loading/unloading and stacking/destacking for semi-rigid and flexible packages such as plastic bottles & pouches.

### Transport Systems

Various alternatives for transport of full & empty baskets or tray stacks to and from the retorts are available: fixed conveyers, shuttle on rails, or automated guided vehicles (AGV).

### Optional Basket Tracking System (BTS)

The Basket Tracking System (BTS) provides the ability to monitor and control the entire ABRS operation remotely. The eyes of the BTS are the RFID readers that identify baskets or tray stacks in key locations of the process (loading, transfer into/out of the retort, cycle start/end, unloading). Our BTS can also track dwell time and other anomalies, which can be rapidly reviewed. Thanks to the excellent system overview provided by our screen visualization, a multi-retort installation can be managed by just a few operators.

## LOG-TEC: Process Management System

JBT's Part 11 compliant LOG-TEC Momentum Process Management system provides a user-friendly interface for review and approval of thermal process cycles. Included are an overview of current phase of each retort, a listing of manual interventions, and a summary of alarms with a quick link to process trending.

This system also provides:

- ✓ **Consistent Process Delivery** due to the self-ran diagnostic test & check prior to start-up
- ✓ **Automatic Process Deviation Correction** for temperature deviations and other process deviations
- ✓ **Central Host PC** is incorporated for easy supervision of retort installation and operates on Windows 64 bit operating systems
- ✓ **USDA/FDA Acceptance**
- ✓ **Safe Record Keeping**
- ✓ **Central Process Recipe Management**
- ✓ **Access Control** to the various functions of the system via password.



## Research & Technology Centers

JBT's Research & Technology Centers (RTC's) maintain simulators & full-size testing equipment with a broad range of data collection capabilities for heat penetration and temperature distribution studies inhouse or at a customer's facility. Based on these studies, JBT can provide Process Letters, Thermal Process Filing (FDA) assistance and process deviation analysis.

### Process Validation

JBT is recognized as a thermal process authority and is in the unique position of being able to offer extensive thermal process expertise regarding virtually all low and high acid foods for nearly every type of sterilization system across a wide variety of package types.

### Thermal Process Development

Our RTC's can simulate most sterilizers and filler-seamers to help you with new sterilization process design, process optimization, can seaming performance, and can/jar filling performance.

### Container Performance Testing

JBT assists with material handling of new packages in existing systems, as well as with development of thermal processing parameters for new container designs.

### Training

Our RTC's around the world provide local support for food processors: Sint-Niklaas (Belgium), Madera (USA), Araraquara (Brazil), and Bangkok (Thailand). We offer thermal process training for line managers and operators (Better Process Control School) as well as Thermal Processing Academy and Aseptic Training.



## SPECIFICATIONS

VESSEL DIAMETER	64" (1626 mm)
NO. OF BASKETS	6, 8, 10, 12
BASKET SIZE BASKET SIZE (INCH [mm])	49.6" [1260] x 42.4" [1076] x 41.1" [1043]
DOOR OPENING	Left hand hinge

## UTILITIES (12 BASKET)

## A-1612-CS

	CONSUMPTION / PROCESS	MAX FLOW
STEAM	6,000 lbs (2,720 kg)	18,000 lb/hr (8,160 kg/hr)
DRAIN (CONDENSATE)	720 gal (2.7 m <sup>3</sup> )	30 gpm (8.2 m <sup>3</sup> /hr)
WATER (COOLING)	43,520 gal (165 m <sup>3</sup> )	1,600 gpm (435 m <sup>3</sup> /hr)
AIR	2,400 SCF (68 Nm <sup>3</sup> )	1,120 SCFM (1,800 Nm <sup>3</sup> /hr)

## HOLDING CAPACITY (PER BASKET)

CAN SIZE	QUANTITY OF CANS PER BASKET PER CAN SIZE
300x407 - Ø73 x 113 mm	2,223 cans/basket
401x400 - Ø99 x 102 mm	1,400 cans/basket
401x411 - Ø99 x 119 mm	1,120 cans/basket
603x600 - Ø73 x 152 mm	336 cans/basket
603x700 - Ø73 x 178 mm	280 cans/basket

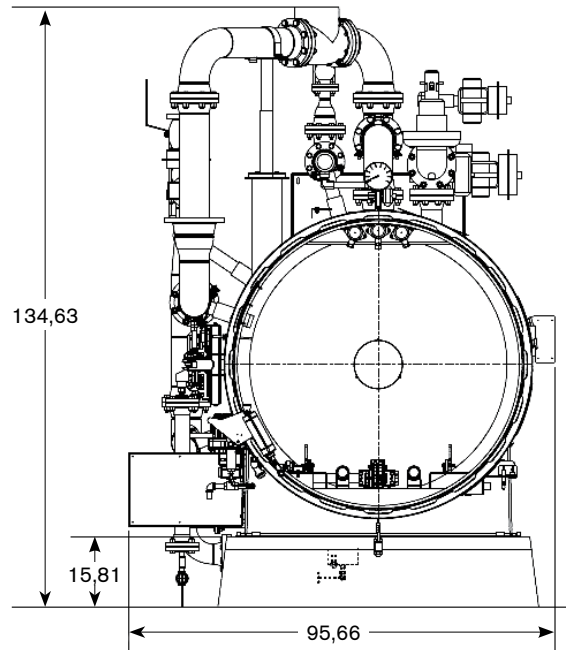

Front view door not shown scale 3:64

## COUNT ON JBT TO HELP PROTECT YOUR INVESTMENT

JBT's greatest value in PRoCARE® services comes from preventing unexpected costs through smart, purposeful, and timely maintenance based on unmatched knowledge and expertise. PRoCARE service packages are offered as a maintenance agreement in various service levels, depending on your production and cost management requirements.



## JBT DIVERSIFIED FOOD & HEALTH

FRESH PRODUCE TECHNOLOGIES | FRESH-CUT, ROBOTICS, STEAMING | FRUIT AND VEGETABLE PROCESSING | SECONDARY PROCESSING | ASEPTIC SYSTEMS | FILLING AND CLOSING | IN-CONTAINER STERILIZING | TRAY SEALING | SECONDARY PACKAGING | HIGH-PRESSURE PROCESSING | POWDER PROCESSING | TUNA PROCESSING

## OUR BRANDS



### Europe

John Bean Technologies NV  
Breedstraat 3  
9100 Sint-Niklaas  
Belgium  
Phone: +32 3 780 1211  
Fax: +32 3 777 7955

### North America

John Bean Technologies Corporation  
2300 Industrial Avenue  
Madera CA 93639  
USA  
Phone: +1 559 661 3200  
Fax: +1 559 661 3156

### South America

John Bean Technologies Máq.  
e Equip. Ind. Ltda.  
Av. Eng Camilo Dinucci 4605  
14808-900 Araraquara, São Paulo  
Brazil  
Phone: +55 16 3301 2000  
Fax: +55 16 3301 2144

### Latin America

JBT de México S de RL de CV  
Camino Real a San Andrés Cholula No. 2612  
Col. San Bernardino Tlaxcalancingo  
72820 San Andrés Cholula, Puebla  
México  
Phone: +52 222 329 4902  
Fax: +52 222 329 4903

### Asia Pacific

John Bean Technologies (Shanghai) Co., Ltd.  
Room 1908, Hongwell International Plaza,  
1600 West Zhongshan Road,  
Xuhui District, Shanghai 200235,  
PRC  
Phone: +86 21 3339 1588  
Fax: +86 21 3339 1599

John Bean Technologies (Thailand) Ltd.  
No. 2525 FYI Center Building 2, 9<sup>th</sup> Floor  
Unit No. 2/901-2/903, Rama IV Road  
Klongtoei, Bangkok 10110  
Thailand  
Phone: +66 (0) 2257 4000  
infoasia-jbtfoodtech@jbt.com

### South Africa

John Bean Technologies (Pty) Ltd.  
Koper Street  
Brackenfell  
Cape Town, South Africa 7560  
Phone: +27 21 982 1130  
Fax: +27 21 982 1136



We're with you, right down the line.™

hello@jbt.com | [jbt.com](http://jbt.com)

