



STEIN

TwinDrum™ 600

Spiral Oven



Efficient two-zone spiral cooking from the oven experts



Stein TwinDrum™ 600 Spiral Oven



Latest twin drum oven design that raised the standards in performance and operating costs

Versatile machine for cooking a wide range of food products. Provides uniform cooking and colour development. Innovations in belt drive and air circulation systems reduce maintenance cost.

Building heritage

- The new Stein TwinDrum Spiral ovens are built on the heritage of decades of oven engineering
- Craftsmanship of full in-house manufacturing and assembly of ovens

Fresh Approach to Air flow

- Our extensive air flow experience and the latest simulation technologies provide an advanced oven design
- The TwinDrum airflow uniformity challenges any system currently available

Superior Yield

- Minimal air temperature variation provides basis for optimized cooking
- The TwinDrum oven enables processors to increase the processing yield over existing ovens

Colour development

- High air speed and uniform distribution assist the development of colour on products.
- Temperatures of up to 250°C will boost the colour effect
- No need for expensive upgrades to provide uniform colour
- Virtually no difference on product colour across the oven belt

2-zone cooking

- Each zone can create its own cooking environment.
- Independent control of humidity, temperature and air speed enables operators to setup the oven to the optimal cooking condition

Humidity control

- Oven is equipped with new humidity sensors for improved reliability and process control
- Automatically controlled venting system can actively reduce humidity levels in the oven to enhance the browning effect on products



Low Maintenance

- Oven designed with low maintenance in focus
- Circulation fans installed on floor level create unrestricted access for maintenance and inspection
- Oven hood free of wiring and parts, improves the reliability
- Screw jack driven hood lift has safety build into the design

Drum drive

- Independent direct drive for each oven drum allows for automatic slip control
- This system reduces belt tension significantly and will reduce maintenance

Reduced amount of glide strips

- The amount of glide strips in the machine has been significantly lowered
- This reduces maintenance costs and down time

Oven height

- The Stein TwinDrum oven has a low profile and can fit in rooms where height is limited
- Unique split-level hood will allow full access to the heating coils as well as the bottom of the oven

Integrated low volume cleaning system

- Cleans the inside of the oven via an efficient cleaning agent distribution
- Drums of the oven are equipped with belt spraying system to enhance the cleaning effect
- Fully automatic system that can be programmed to provide a short cleaning cycle
- Low volume system reduces cycle times, cleaning agent consumption and energy usage
- Water management stops the unnecessary wastage of water during cleaning
- Optional conductivity sensor allows the system to operate with the optimal cleaning agent concentration maximizing the effect of the cleaning agents

Belt washing system options

- The belt washing system is flexible by design. It can be located in front or after the oven
- Easily removable brushes enable deep cleaning and fast change over

Energy reductions

- The TwinDrum oven is equipped with various energy saving technologies to keep the operating costs low
- Automatic water management system reduces the water consumption during running to a minimum
- Hot belt return limits energy losses when belt is returned to infeed
- Independent cooking zone control keep air and steam contained inside the oven

Stein TwinDrum™ 600 Spiral Oven

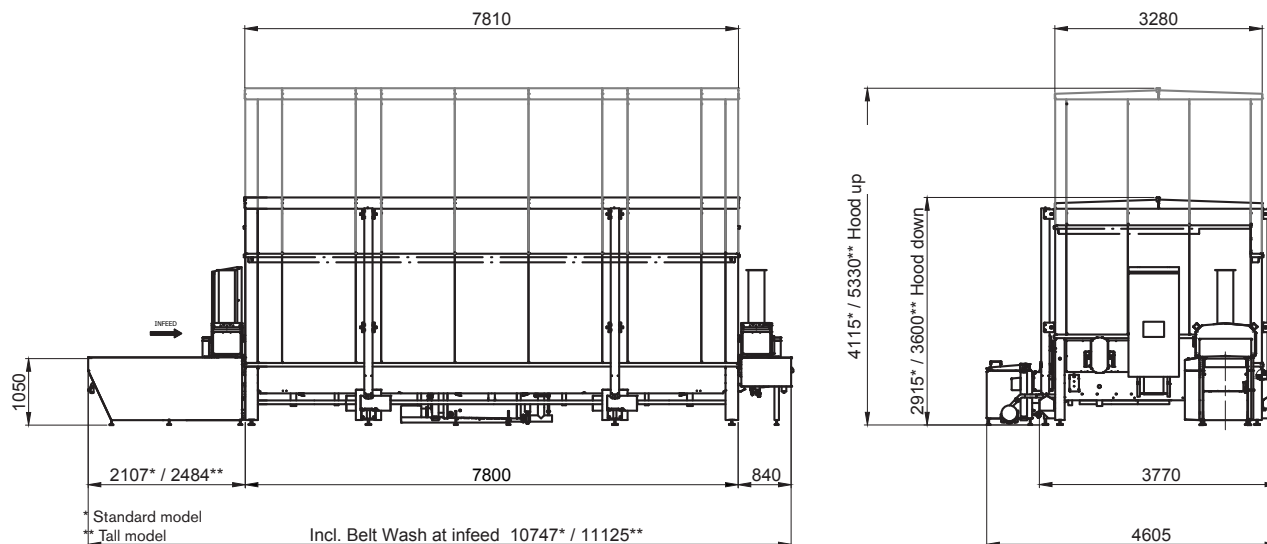

WE ARE YOUR SINGLE SOURCE FOR PROFITABLE PROCESSING SOLUTIONS

JBT is a leading provider of integrated food processing solutions. From single machines to complete processing lines, we enhance value and capture quality, nutrition and taste in food products. With a local presence on six continents, JBT can quickly provide our customers and partners in the food processing industry with the know-how, service, and support needed to succeed in today's competitive marketplace.



FRIGOSCANDIA

STEIN

DSI



SCHRÖDER



North America

JBT Corporation
1622 First St.
Sandusky, OH 44870
USA
Phone: +1 419 626 0304
E-mail: process-solutions@jbt.com

Europe

John Bean Technologies AB
Rusthällsgatan 21, Box 913
SE-251 09 Helsingborg
SWEDEN
Phone: +46 42 490 4000
info-europe@jbt.com

Asia

John Bean Technologies Ltd.
159/26 Serm-Mit Tower, Room no. 1602-3
Sukhumvit 21 Road, Klongtoey Nua Sub-district
Wattana District, Bangkok 10110, THAILAND
Phone: +66 2257 4000
E-mail: infoasia-jbtfoodtech@jbt.com

Latin America

John Bean Technologies
Máquinas e Equipamentos Industriais Ltda.
Av. Eng. Camilo Dinucci 4605
14808-900 Araraquara, São Paulo, BRAZIL
Phone: +55 16 3301 2000
E-mail: latinamerica.info@jbt.com



We're with you, right down the line.™

jbt.com/foodtech