

SIDE VIEW

30 Ton IceCat Ice Maker Specifications

- (1) REQUIRED NOMINAL 60 T.R. @ 0° OF SUCTION
- (2) Pressure Rating = 250 PSIG @ 350°F
- (3) All Stainless Frame Construction
- (4) All Control Valves Have Hand Isolation Valves
- (5) Sanitary Water Supply Reservoir
- (6) Sanitary Water Circulating Pump - 1.5 HP 480 VAC 60HZ 3 PH 30 AMP
- (7) 120 Volt Control Voltage 5 Amp - TouchScreen & Controls
- (8) Make-Up Water - Minimum 30 GPM to allow for Fast Fill .
- (9) Ammonia Charge - 640 lbs.
- (10) ICE MAKER ASSEMBLED WEIGHT = 7,025 LBS.
- (11) ICE MAKER OPERATING WEIGHT = 8,315 LBS.

NOTE:
 1. ICE MAKER VESSEL, WATER PUMP AND STAINLESS PIPE TO BE ASSEMBLED IN SHOP AND MOUNTED ON FRAME.
 2. SURGE TANK AND STAND ASSEMBLED IN SHOP.

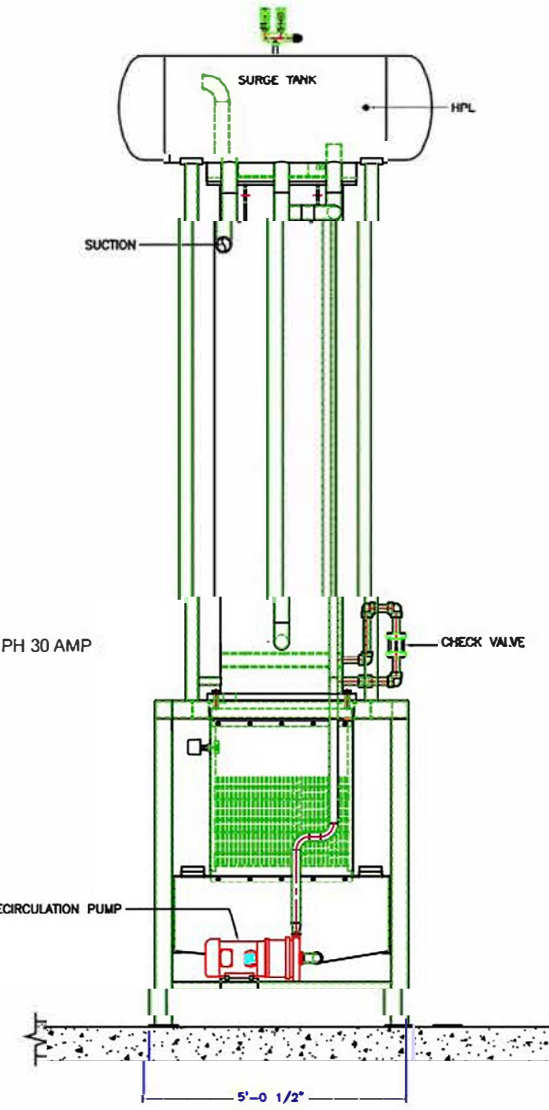

BACK VIEW

THIS DOCUMENT AND ITS CONTENTS ARE PROPRIETARY TO COOLING AND APPLIED TECHNOLOGY, INC. ANY REPRODUCTION, DISCLOSURE OR USE OF THIS DOCUMENT IS EXPRESSLY PROHIBITED EXCEPT AS AGREED TO IN WRITING BY COOLING AND APPLIED TECHNOLOGY, INC.



REV.	DATE	REVISIONS

--	--	--	--	--	--

--	--	--	--	--	--

