



**STRONGER  
TOGETHER**

**PRIME  
EQUIPMENT GROUP**  
Simple Solutions for Poultry Processing

## Keel Strip Remover for Turkey

Model No. KSR-1T



The KSR-1T Turkey Keel Strip Remover is designed to remove the keel strip from a full turkey breast fillet, cutting the fillet into three pieces: two breast lobes and a center keel strip. Its high degree of accuracy and consistency improves yields over hand processing, and requires only a single loader in a low-stress capacity that does not require extensive trim training.

See Prime in action: View  
[www.PrimeEquipmentGroup.com/videos](http://www.PrimeEquipmentGroup.com/videos)

Viewing online?  
Click here

EFFICIENT, EFFECTIVE, CONSISTENT  
KEEL STRIP REMOVAL

POSITIONED DOWNLINE FROM  
WHOLE BREAST REMOVAL

EFFECTIVE AT UP TO 30 WHOLE  
BREASTS PER MINUTE



### PRIME ROI:

IMPROVES YIELD VS. MANUAL KEEL STRIP REMOVAL

REDUCES LABOR: ONLY A SINGLE LOADER NEEDED

SIMPLE LOADING OPERATION ELIMINATES TRAINING

NEEDS FOR MANUAL TRIMMING

2001 Courtright Road  
Columbus, OH 43232 USA

Please call  
[+1 \(614\) 253-8590](tel:+16142538590)

Send us an email  
[Sales@PrimeEquipmentGroup.com](mailto:Sales@PrimeEquipmentGroup.com)

More info  
[PrimeEquipmentGroup.com](http://PrimeEquipmentGroup.com)



**STRONGER  
TOGETHER**

**PRIME  
EQUIPMENT GROUP**  
Simple Solutions for Poultry Processing

# Keel Strip Remover for Turkey

Model No. KSR-1T

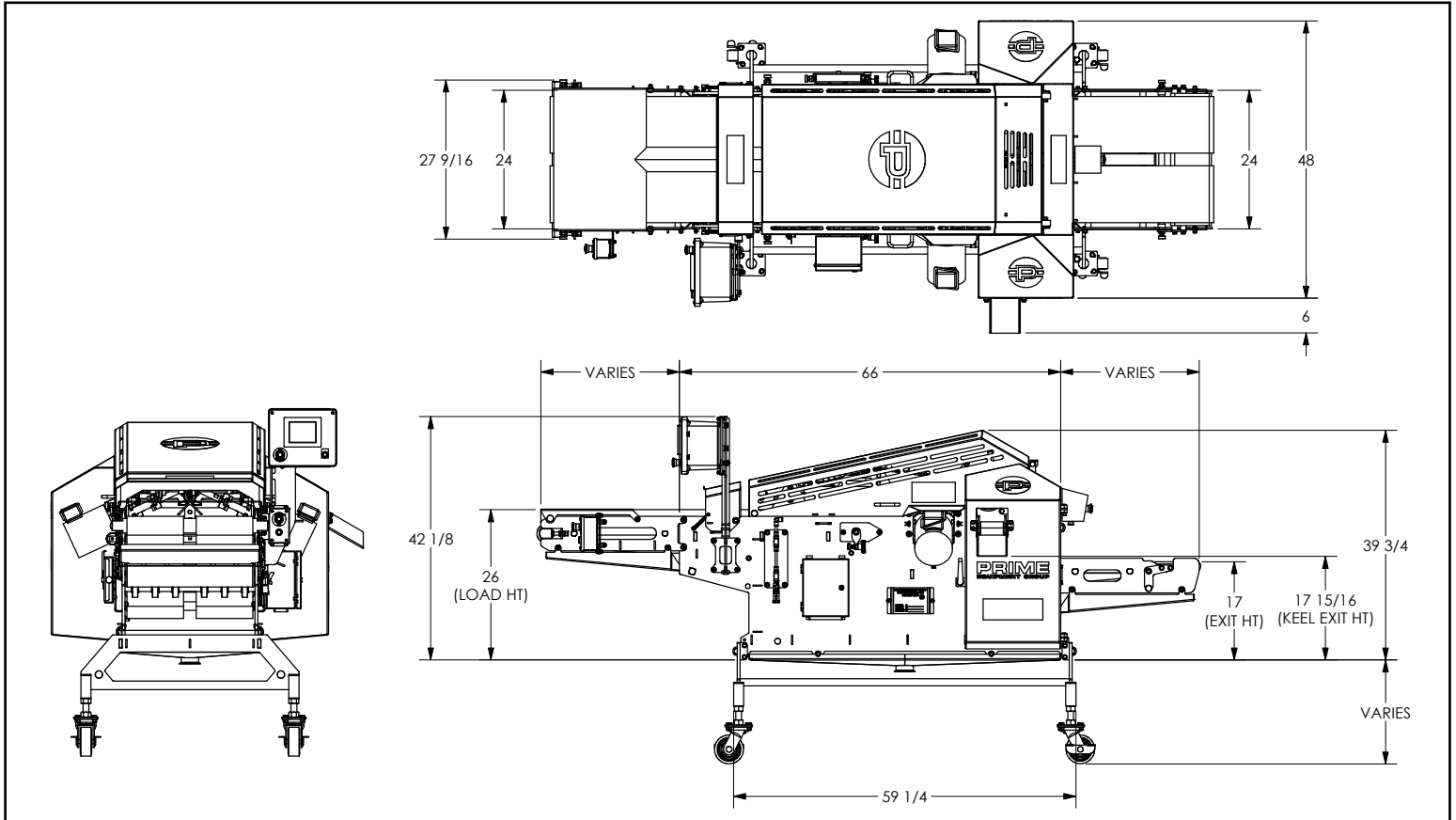

## TECHNICAL SPECIFICATIONS

Electrical Requirements:	(1) 2 hp motor, 480/3ph/60Hz/15A (2) 1/2 hp motors, 480/3ph/60Hz/15A
Water Requirements:	(1) 1/4" NPT connection; 2.0 GPM, 40 PSI minimum, room temperature.
Weight:	600 lbs
Production Rate:	Up to 30 Hen/Tom breasts/min
NOTE: Specifications are accurate at time of publication	