

Valve Rebuild Program for Rotary Sterilizers

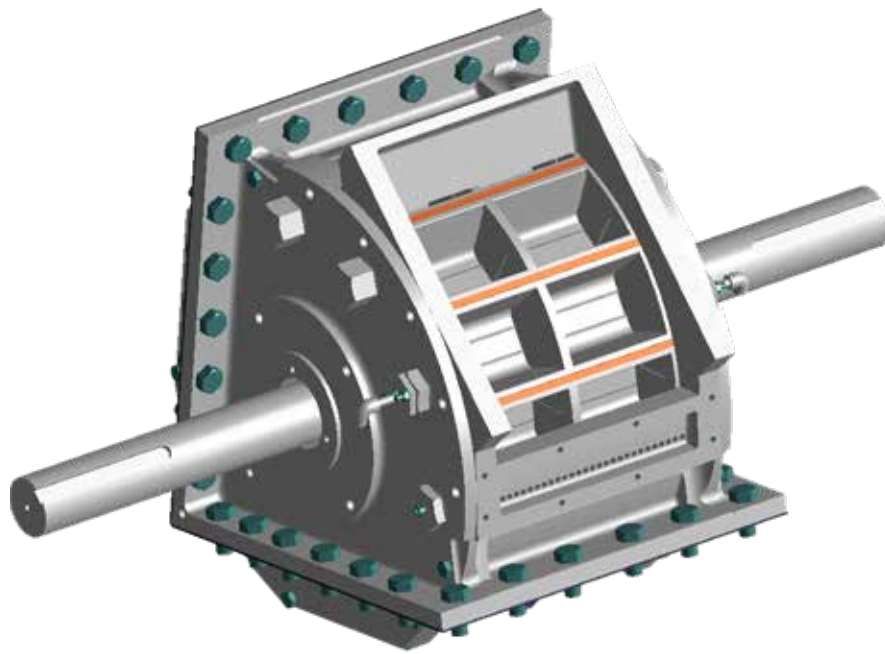

High-quality revision of your original set
by experienced JBT mechanics



PRoCARE®

The smart way to produce
more tonnage per day

jbt.com

Upgrade to the latest version

A new type of side seal rings which seal the rotor inside the valve are available; this ring is slightly different from the 'old' standard rings and shows far better sealing properties which have advantages in multiple ways:

- ✓ Reduced consumption/loss of steam
- ✓ Reduced loss of oil
- ✓ Reduced level of noise

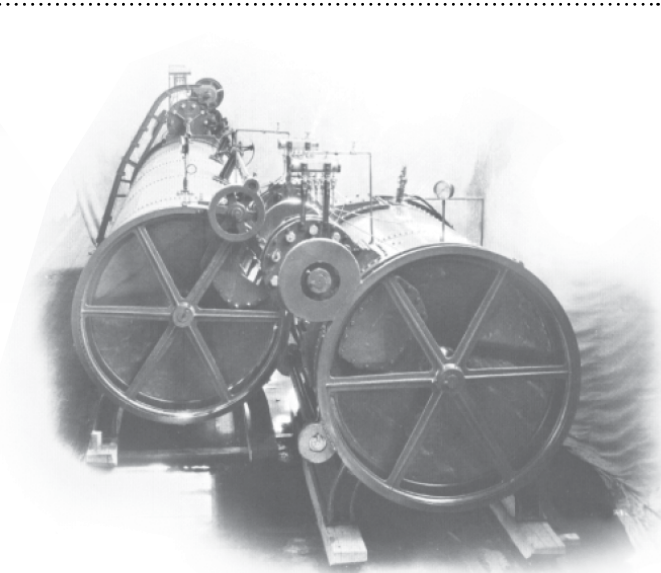

The new ring has no slot anymore and is equipped with an O-ring on its shoulder to seal off against the valve housing. The new rings are compatible and can be installed on older/other valves.



Pre-run test of the overhauled units

All units will be get a test run on our test stand and we can provide a report of this. By doing this we can assure there are no leaks and check whether the power take-off from the valve is within range.

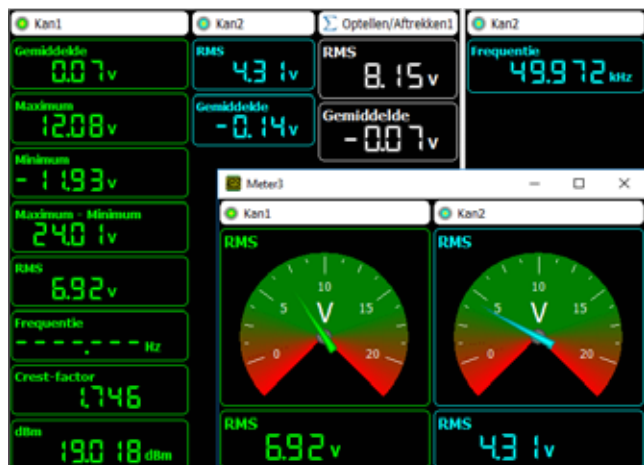

Benefits

- **Lower maintenance and warehousing costs**
No need to have each individual spare part in your own stock.
- **Reduce downtime / increase production time**
Replacement and revision of your valve with individually sourced spare parts takes significant more working hours compared to a rebuild at JBT factory.
- **Your assemblies are shipped and stored in a secured and dedicated flight case.**
- **All parts will be checked on wear and play (Rotor, housing, axle, bearings, springs, pockets).**



Rotary Sterilizer Valve Rebuild work flow

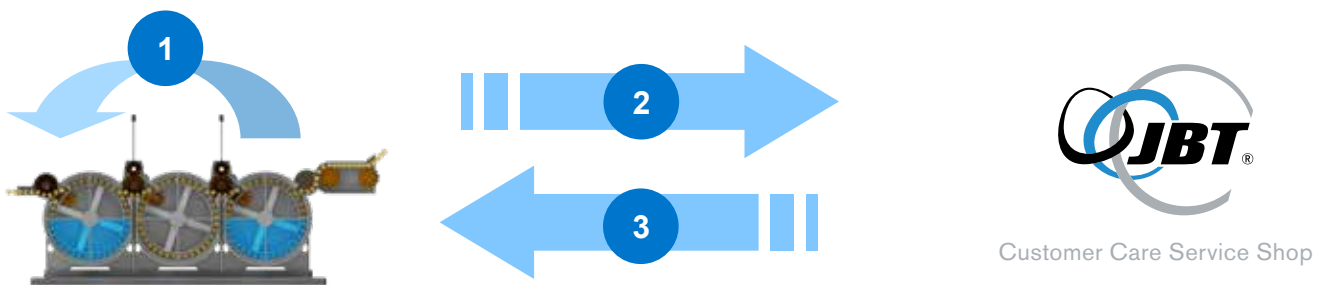

- Step 1:** Replace on site the valve (inlet | transfer | Discharge) by a pre-assembled spare
- Step 2:** Send valve back to JBT with order for disassembly, cleaning & full inspection
- Step 3:** Receive inspection report and detailed offer to rebuild valve
- Step 4:** Upon order receipt, JBT will revise the valve, conduct a run test at a pilot sterilizer and return it back to your manufacturing location. – (STEP1)

Note: As an alternative the revision of the valve can be performed at your workshop. Disadvantage is that valve will not be tested before retuning in your spares inventory.

JBT Continuous Rotary Pressure Sterilizer

Since 1921, more than 7,500 Continuous Rotary Pressure Sterilizers have been placed into production around the world and are processing over half the world's canned foods. Year-by-year JBT has advanced the rotary sterilizer technology to offer high, consistent product quality at the lowest cost per unit produced. Today's rotary pressure sterilizer technology allows processors to handle traditional and modern, stackable, light-weight and easy open-end cans. There simply is no better way to sterilize high volumes of convection type foods in cylindrical metal containers.

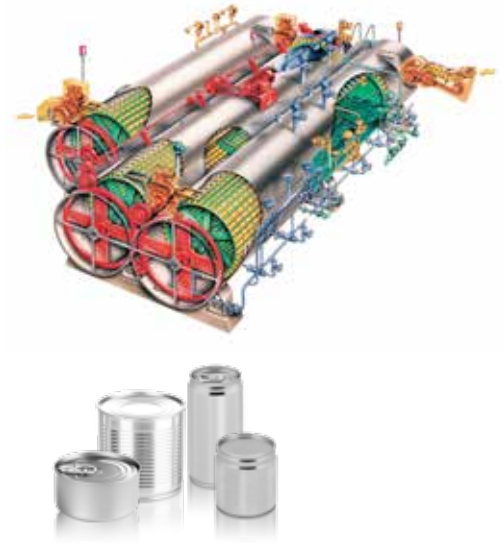

Contact for Valve Rebuild Program

John Bean Technologies NV - Breedstraat 3 - 9100 Sint-Niklaas | Belgium

24/7 Help Desk: +32 3 780 1444

Service Assistance: service.sn@jbt.com

Parts Assistance: parts.sn@jbt.com

Sales: sales.sn@jbt.com.

COUNT ON JBT TO HELP PROTECT YOUR INVESTMENT

JBT's greatest value in PRoCARE® services comes from preventing unexpected costs through smart, purposeful, and timely maintenance based on unmatched knowledge and expertise. PRoCARE service packages are offered as a maintenance agreement in various service levels, depending on your production and cost management requirements.



JBT DIVERSIFIED FOOD & HEALTH

FRESH PRODUCE TECHNOLOGIES | FRESH-CUT, ROBOTICS, STEAMING | FRUIT AND VEGETABLE PROCESSING | SECONDARY PROCESSING | ASEPTIC SYSTEMS | FILLING AND CLOSING | IN-CONTAINER STERILIZING | TRAY SEALING | SECONDARY PACKAGING | HIGH-PRESSURE PROCESSING | POWDER PROCESSING | TUNA PROCESSING

OUR BRANDS



Europe

JBT Food & Dairy Systems
Deccaweg 32
1042 AD Amsterdam - The Netherlands
Phone: +31 20 634 8911
Fax: +31 20 636 9754
info.ams@jbt.com

JBT Food & Dairy Systems SARL
La Frégate - Bâtiment B
1901 Avenue Jacques Cartier
44800 Saint Herblain
France
Phone: +33 02 3762 5700

John Bean Technologies NV
Breedstraat 3
9100 Sint-Niklaas
Belgium
24/7 Help Desk: +32 3 780 1444
Service Assistance: service.sn@jbt.com
Parts Assistance: parts.sn@jbt.com

John Bean Technologies SpA
Via Mantova 63/A
43122 Parma
Italy
Phone: +39 0521 908 411
service.parma@jbt.com

John Bean Technologies Foodtech Spain S.L.
Autovía A-2, Km 34,400 - Edificio 1 y 3
28805 Alcala de Henares
Madrid, Spain
Phone: +34 91 304 0045
Fax: +34 91 327 5003

John Bean Technologies Sp. z o.o.
ul. Przy Bazantarni 11
02-793 Warszawa, Poland
Phone: +48 22 894 9025
Fax: +48 22 894 9041

JBT Corporation
Petrovka str. 27
Moscow, Russia 107031
Phone: +7 495 221 87 13
Phone: +7 495 221 87 14 (2 lines)

North America

John Bean Technologies Corporation
400 Fairway Avenue
Lakeland, FL 33801
USA
Phone: +1 863 683 5411
Fax: +1 863 680 3672

South America

John Bean Technologies Máq.
e Equip. Ind. Ltda.
Av. Eng Camilo Dinucci 4605
14808-900 Araraquara, São Paulo
Brazil
Phone: +55 16 3301 2000
Fax: +55 16 3301 2144

Latin America

JBT de México S de RL de CV
Camino Real a San Andrés Cholula No. 2612
Col. San Bernardino Tlaxcalancingo
72820 San Andrés Cholula, Puebla
México
Phone: +52 222 329 4902
Fax: +52 222 329 4903

Asia Pacific

John Bean Technologies (Thailand) Ltd.
No. 2525 FYI Center Building 2, 9th Floor
Unit No. 2/901-2/903, Rama IV Road
Klongtoei, Bangkok 10110
Thailand
Phone: +66 (0) 2257 4000
infoasia-jbtfoodtech@jbt.com

South Africa

John Bean Technologies (Pty) Ltd.
Koper Street
Brackenfell
Cape Town, South Africa 7560
Phone: +27 21 982 1130
Fax: +27 21 982 1136

John Bean Technologies (Shanghai) Co., Ltd.
Room 1908, Hongwell International Plaza,
1600 West Zhongshan Road,
Xuhui District, Shanghai 200235,
PRC
Phone: +86 21 3339 1588
Fax: +86 21 3339 1599



We're with you, right down the line.™

hello@jbt.com | jbt.com

