

GT6eX/Twin

The GT6eX/Twin is an automatic, large-capacity tray sealing system designed for high-speed production, efficiently cutting labour costs. Available in 2 formats; standard twin-lane or extra-wide-single-lane capable of taking packs up to 400mm wide long edge leading into the machine.

Capable of **192 Vacuum/Gas packs** per minute on a 16 impression tool, the **GT6eX-Twin** is a high throughput modular, twin-lane, linear, heat-sealing system. It is designed to run in conjunction with auxiliary equipment such as tray de-nesters, fillers, multi-head weighers and labellers, combining into a stand-alone, fully automatic production line.

At the core of the 'e' design is its flexibility to perform any style of heat seal to a pre-formed tray, be that atmospheric, MAP, VMAP, Skin, Skin Plus, or Skin Deep. Each of these options can be added now or at a later date, or indeed removed as necessary. This flexibility provides the user with the assurance that whatever the latest packaging trend might be, they have equipment suitably geared for the future.

Designed to accept randomly spaced trays from any conveyor and can be fully integrated with other line equipment.

Packaging Materials

Trays

- C-PET
- A-PET
- R-PET
- Polypropylene
- PVC / Styrene
- Board / Paper
- Smooth Wall Foil

Lidding

- Co-extruded and Laminated Polyester Films
- Foil
- Board
- Paper

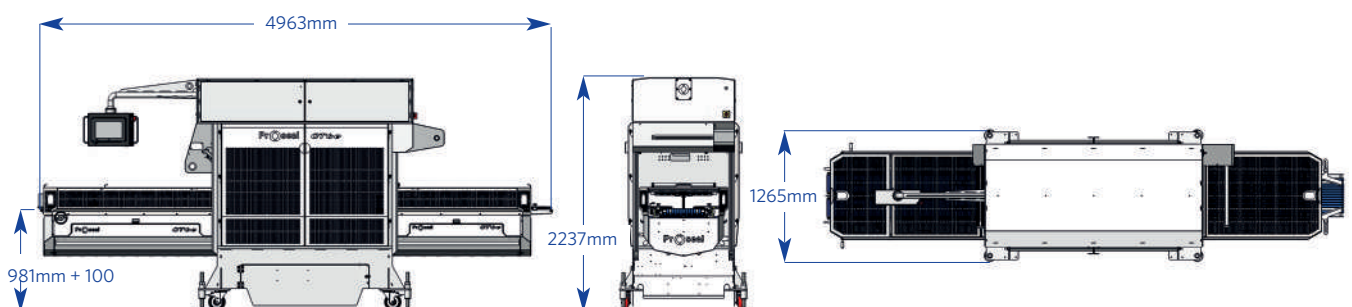

Standard design features and benefits

- Five minute tool changeover
- Low maintenance polymer bearings
- Simple and accurate film-feed system with easy film route
- Maintenance friendly robust construction
- Accurate temperature and seal pressure control
- High accuracy tool alignment system provides a constantly accurate sealing and/or film-cutting relationship with the tray flange profile
- Simple design and operation
- Film snap detection
- 'Auto Tool' Touch of a button tool change system, automatically locates and connects tooling to machine functions including all MAP options
- Integration of peripheral equipment, such as: infeed and outfeed conveyors, checkweighers, metal detectors and printers.
- All around seal and contoured film-cut with skeletal film rewind
- Automatic seal operation with accurate seal dwell time
- Self-centring tray guides
- Automatic film roll clamping
- Food industry approved hygienic construction and wash-down protection
- Full Category 3 guarding
- User friendly, menu-driven control panel with step-by-step prompts, error and status displays, and useful batch pack counter
- Recipe handling of machine settings
- Self diagnostic system
- Pendant mounted colour touch screen HMI control for full double-sided operation
- Recipe driven auto machine set-up for tool change
- On-screen data capture and trends with wireless connection option
- Pot crush avoidance system
- Active film tension
- **QRconveyors** with quick release belts for easy hygiene and maintenance
- **Eseal®** - high-performance, high-precision, high-force, energy-efficient, electric seal system that boasts a massive increase in seal force
- **Promotion** - a high accuracy continuous motion tray infeed system, which increases production speed whilst reducing machine duty

GT6eX / GT6eX Twin Specifications

Height	2237mm
Standard Length	4963mm
Width	1265mm
Weight	2300kg + specification dependent
Electrical Supply	400V 3 phase + neutral (fused at 32A)
Transformer Variations	480V 3 phase (fused at 25A) 600V 3 phase (fused at 20A)

Metric

Imperial

Pressure	Flow	Pressure	Flow
6 Bar	50L/Min	87psi	1.7CFM
Required Supply for Skin Machine (SD spec)			
6 Bar	707L/Min	87psi	25CFM

Transformers are available to accommodate the electrical supplies in different countries

Options available

- Free flow gas flush MAP (Modified Atmosphere Packaging)
- High Oxygen (O²) gas flush
- **Vacuum** - used for applications such as retorting or for when the lid level needs to be controlled
- **Vacuum Gas** - ideal for where residual gas levels have to be sub 1%
- **Skin** - Skin packaging sub flange
- **Skin Plus** - Skin packaging up to 50mm above the tray flange
- **Skin Deep** - Skin packaging up to 100mm above the tray flange
- **Close Cut** - Method of maximising throughput and reducing film waste
- **Inboard Cut (IC)** option to provide 'form, fill and seal' tray presentation
- Film coding and printing
- Foil crimping
- Active conveyors to allow the machine to be used as a straight through conveyor when packs don't require sealing
- Back-to-back machine configurations
- Optional integration of peripheral equipment, such as: denesters, fillers, multi-head weighers, laser coders, labellers
- **eWON** - a machine connection system to deliver real time data and error condition support, remote setup, and software upgrades, using a customer's existing IT network
- **I-film** - intelligent film reel monitoring system which actively adjusts film tension based on reel diameter to increase print quality and film reel efficiency, reduce component duty, and provides a film end warning system
- **Protect** - a contactless machine login and audit trail system
- Sale, Lease Purchase and Rental options available

GT6eX Sealing capacity

No. of trays	Width	Length	Depth	Diameter
Two	420mm	631mm	120mm	420mm
Three	420mm	412mm	120mm	412mm
Four	420mm	302mm	120mm	302mm
Five	420mm	237mm	120mm	237mm
Six	420mm	193mm	120mm	193mm
Seven	420mm	162mm	120mm	162mm
Eight	420mm	138mm	120mm	138mm

GT6eX Twin Sealing capacity

No. of trays	Width	Length	Depth	Diameter
Four	200mm	631mm	120mm	200mm
Six	200mm	412mm	120mm	200mm
Eight	200mm	302mm	120mm	200mm
Ten	200mm	237mm	120mm	200mm
Twelve	193mm	193mm	120mm	193mm
Fourteen	162mm	162mm	120mm	162mm
Sixteen	138mm	138mm	120mm	138mm



PRODUCE | C-PET



READY MEALS | C-PET



PRODUCE | A-PET



FRESH MEAT | POLYPROP



SEAFOOD | A-PET

for more information UK +44 (0) 1625 856 600 America +1 804 447 9038 Australia +61 (0) 3 9397 0955

www.proseal.com