

# Formula 2350 H1

## Food Grade Silicone Fluid



JBT FoodTech Formula 2350 H1 Food Grade Silicone Fluid is for specific lubrication and cleaning applications involved with the operation of our Low-Tension Equipment. Refer to your equipment manual for the exact instructions on proper application. The diagram points out the components, particularly the reservoir, which should be checked daily to ensure sufficient Formula 2350 is present to perform this vital operation. The fluid is formulated to provide smoother, tensionless movement of the belting over the track. Unlike non-recommended lubricants, Formula 2350 Silicone Fluid will not become gummy or tacky, and has no opportunity for rancidity like vegetable based products. Formula 2350 will help reduce cage amperage draw when used as recommended therefore saving energy as well.

### Components

1. Flip-up lid
2. Reservoir
3. Needle valves
4. Lubricating brushes

The reservoir should be filled as needed with Formula 2350 silicone lubricant. Needle valves can be adjusted to maintain the optimum feed rate. Fill the reservoir via the flip-up lid.

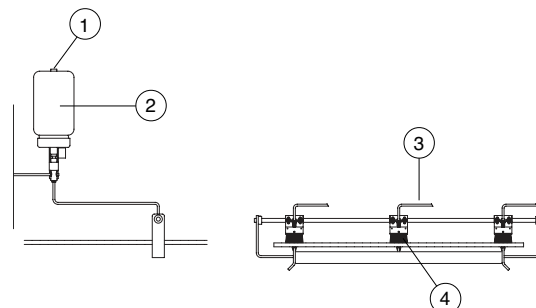

## Formula 2350 H1 Food Grade Silicone Fluid.

### Features

- Low Surface Energy
- Very Little or No Odor
- Withstands Low Serviceability Temperatures
- Low Environmental and or Fire Hazard
- High Oxidation Stability
- High Water Repellency

### Benefits

- Water Clear Color so Belts Do Not Darken
- Will not Turn Rancid/Spoil
- Totally Tasteless so No Chance of Flavor Transfer
- Will Not Build Up and Turn Tacky or Gummy
- Keeps Belts Sliding as Intended to Save on Draw
- Keeps Tension Low

Typical Properties	2350
Viscosity @ 25°C, cSt	350.0
Viscosity @ 40°C, cSt	266.0
Viscosity @ 100°C, cSt	108.4
Viscosity Index	433
Pour Point, °F	-85
Pour Point, °C	-65
Flash Point, °F	689
Flash Point, °C	365
Specific Gravity @ 77°F(25°C)	0.9765
Density, lbs/gal	8.1
Dielectric Strength @ 77°F(25°C) volts/mil	400
Texture	Light Syrup
Color	Water White
MICRONOX®	Yes

Meets requirements for H1 Incidental Food Contact



### Part Numbers:

**N0120021** 4/1 Plastic Gallon Bottle

**N0120022** 5 Gallon Round Plastic Pail

Designed specifically for JBT FoodTech Low-Tension Freezing Equipment using the JBT FoodTech track oiler as shown on the other side of this document. The feed rate of the oiler is entirely dependent on the spiral dimension, speed, temperature and application. This rate should be adjusted to balance and economize the oil while maintaining acceptable belt tension.

**To place an order or receive additional information call:  
Order Entry Department 507-645-9546, 800-408-7788 option 3,  
Fax 507-645-9664, email: [frigostein.info@jbt.com](mailto:frigostein.info@jbt.com)**

[www.jbtfoodtech.com](http://www.jbtfoodtech.com)



JBT FoodTech  
1700 Cannon Road  
Northfield, MN 55057  
Phone: +1 507 645 9546  
Fax: +1 507 645 9664  
Email: [frigostein.info@jbt.com](mailto:frigostein.info@jbt.com)