

Options & Upgrades



Complete Spare Assemblies for JBT seamers

FC01 Chuck Shafts | FC02 Lifters



PRoCARE®

The smart way to produce
more tonnage per day

jbt.com/foodtech

Complete Spare Assemblies - Your benefits

- **Reduce downtime / increase production time**

Replacement and revision of the original chuck shafts and (stopping) lifters by separate spare parts takes 50 working hours instead of 10 hours when using the complete spare assemblies. The use of pre-assembled chuck shafts and (stopping) lifters will hence significantly reduce your downtime during planned maintenance stops.

- **Instant on-site availability of critical assemblies in case of breakdown**

In case of breakdown your maintenance team can immediately carry out the repair work. No waiting times for ordering, processing the parts and transport.

- **Reduce maintenance costs & warehousing costs**

A Complete Spare Assembly represents 1 Stock Keeping Unit (SKU) instead of more than SKUs for the separate spare parts.

- **High-quality revision of your original set by experienced JBT mechanics, at the latest execution**

The revision of the part assemblies can be performed off-line - and not in the high-care zone - by JBT mechanics or own technicians at your location. Another option is to perform the revision by JBT technicians in the JBT Customer Care workshop in Sint-Niklaas (Belgium). In this case the revision takes place in the most recent version and a pre-run test of the overhauled units can be performed before shipping them back to your location.

- **Your assemblies are shipped and stored in a secured and dedicated flight case.**



Example of a ROI calculation for 6 sets illustrating a pay-back in approximately 2 running years.

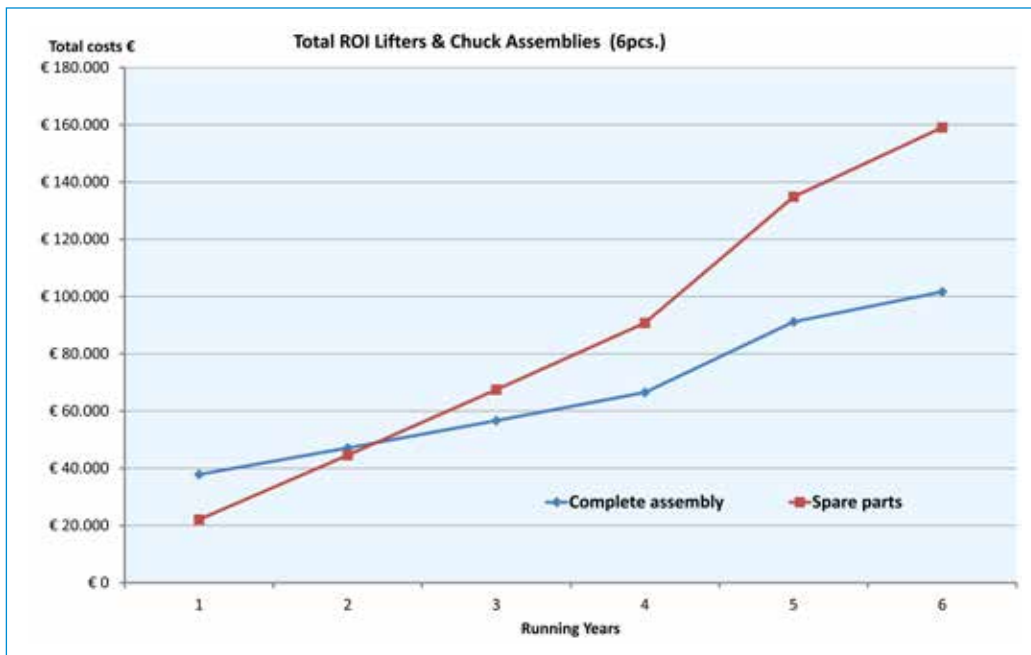

Complete Spare Assemblies - Chuck Shafts FC01

The chuck shaft assembly consists of the following items:

- Knock-out shaft
- Sealed end cap
- Heavy duty drive gear
- Double bearing spindle

Available for all machine versions of SeamTec, X52 and X59

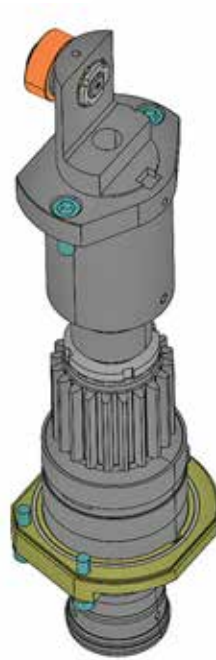

Complete Spare Assemblies - Lifters FC02

The (stopping) lifter assembly consists of the following items:

- Manual adjustable spring load
- Automatic actuated lifting device when load is applied
- Heavy duty drive unit
- Lifter table wear plate
- Built-in oil lubrication & circulation
- Positive raise cam follower
- **Only for powder applications:**
Automatic stopping of rotation when no can or load is applied

Available for all machine versions of SeamTec, X52 and X59

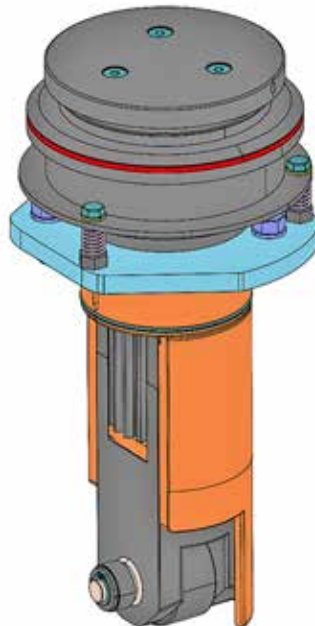

Complete Spare Assemblies - Your benefits

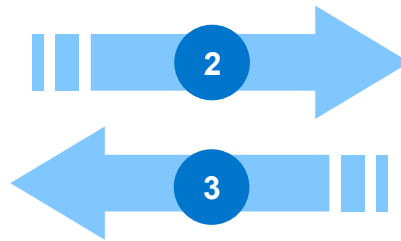
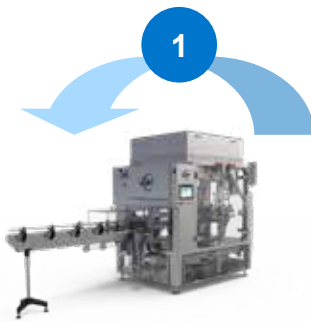

Customer Care Service Shop

Step 1: Replace on-site the original chuck shafts or (stopping) lifters by the Complete Spare Assemblies

Step 2: Send the used chuck shafts or (stopping) lifters to the JBT Customer Care Service Shop

Step 3: JBT will completely revise your original set and send it back to your manufacturing location, ready for the next round (Step 1)

Note: As an alternative - instead of sending the assemblies to JBT - the revision of the part assemblies can also be performed at your workshop either by JBT or your own technicians.

Contact for Complete Spare Assemblies for JBT seamers

John Bean Technologies NV - Breedstraat 3 - 9100 Sint-Niklaas | Belgium

24/7 Help Desk: +32 3 780 1444

Service Assistance: service.sn@jbt.com

Parts Assistance: parts.sn@jbt.com

WE ARE YOUR SINGLE SOURCE FOR PROFITABLE PROCESSING PROCESSING & PACKAGING SOLUTIONS

JBT is a leading provider of integrated food processing and packaging solutions. From single machines to complete processing lines, we enhance value and capture quality, nutrition and taste in food products. With a local presence on six continents, JBT can quickly provide our customers and partners in the food processing industry with the know-how, service, and support needed to succeed in today's competitive marketplace.

JBT LIQUID FOODS

FRESH PRODUCE TECHNOLOGIES | FRUIT AND VEGETABLE PROCESSING | SECONDARY PROCESSING | ASEPTIC SYSTEMS | FILLING AND CLOSING | IN-CONTAINER STERILIZING | HIGH-PRESSURE PROCESSING | POWDER PROCESSING | TUNA PROCESSING

OUR BRANDS



ALSO REPRESENTING



Europe

JBT Food & Dairy Systems
Deccaweg 32
1042 AD Amsterdam - The Netherlands
Phone: +31 20 634 8911
Fax: +31 20 636 9754
info.ams@jbt.com

JBT Food & Dairy Systems SARL
La Frégate - Bâtiment B
1901 Avenue Jacques Cartier
44800 Saint Herblain
France
Phone: +33 02 3762 5700

John Bean Technologies NV
Breedstraat 3
9100 Sint-Niklaas
Belgium
24/7 Help Desk: +32 3 780 1444
Service Assistance: service.sn@jbt.com
Parts Assistance: parts.sn@jbt.com

John Bean Technologies SpA
Via Mantova 63/A
43122 Parma
Italy
Phone: +39 0521 908 411
service.parma@jbt.com

John Bean Technologies Spain, S.L.U.
Autovia A-2, km 34,400
28805 Alcalá de Henares
Madrid, Spain
Phone: +34 91 304 0045
Fax: +34 91 327 5003

John Bean Technologies Sp. z o.o.
ul. Przy Bazantarni 11
02-793 Warszawa, Poland
Phone: +48 22 894 9025
Fax: +48 22 894 9041

JBT Corporation
Petrovka str. 27
Moscow, Russia 107031
Phone: +7 495 221 87 13
Phone: +7 495 221 87 14 (2 lines)

North America

John Bean Technologies Corporation
400 Fairway Avenue
Lakeland, FL 33801
USA
Phone: +1 863 683 5411
Fax: +1 863 680 3672

South America

John Bean Technologies Máq.
e Equip. Ind. Ltda.
Av. Eng Camilo Dinucci 4605
14808-900 Araraquara, São Paulo
Brazil
Phone: +55 16 3301 2000
Fax: +55 16 3301 2144

Latin America

JBT de México S de RL de CV
Camino Real a San Andrés Cholula No. 2612
Col. San Bernardino Tlaxcalancingo
72820 San Andrés Cholula, Puebla
México
Phone: +52 222 329 4902
Fax: +52 222 329 4903

Asia Pacific

John Bean Technologies (Thailand) Ltd.
No. 159/26 Serm-Mit Tower 16th Floor
Room no. 1602-3 Sukhumvit 21 Road
Klongtoey Nua Sub-district, Wattana District
Bangkok 10110 Thailand
Phone: +66 2 257 4000
Fax: +66 2 261 4099

South Africa

John Bean Technologies (Pty) Ltd.
Koper Street
Brackenfell
Cape Town, South Africa 7560
Phone: +27 21 982 1130
Fax: +27 21 982 1136

John Bean Technologies (Shanghai) Co., Ltd.
Room 1908, Hongwell International Plaza,
1600 West Zhongshan Road,
Xuhui District, Shanghai 200235,
PRC
Phone: +86 21 3339 1588
Fax: +86 21 3339 1599

We're with you, right down the line.™

hello@jbt.com | jbt.com/foodtech

