

MODEL FILE: 70025600

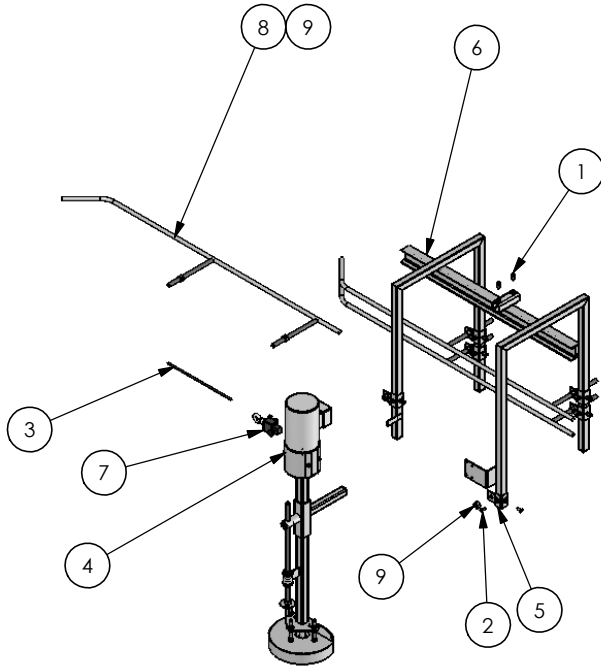
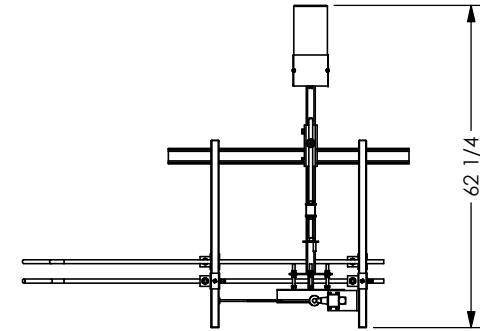
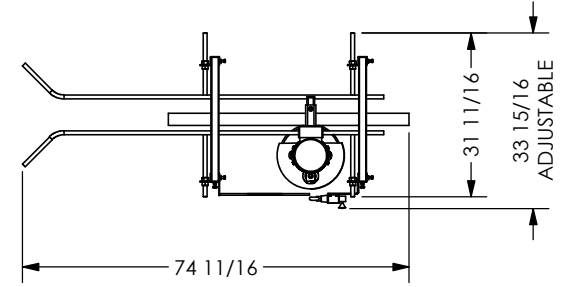
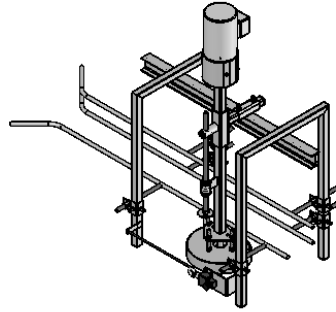

| ITEM NO. | QTY. | PART NUMBER | DESCRIPTION                       |
|----------|------|-------------|-----------------------------------|
| 9        | 12   | FHNS075C    | NUT,FNSH,HEX,3/4-10,SS            |
| 8        | 3    | 70025617    | BAR,GUIDE,REAR HALF BSC           |
| 7        | 1    | 70025616    | SW,SAFETY,440E-D13120             |
| 6        | 1    | 70025611    | WLDMNT,FR,BSC                     |
| 5        | 6    | 70025610    | BLOCK,GUIDE,BSC                   |
| 4        | 1    | 70025600-01 | MOTOR/BLADE ASSY,BSC              |
| 3        | 2 FT | 70025204    | ROPE,WIRE,NYLON COATED,RED        |
| 2        | 12   | 33842       | SCR,SET,SQ HD,3/8-1 6X1,SS        |
| 1        | 2    | 18490       | SQHD CUPPOINT SETSCREW 1/2-13X1SS |

| C  | -     | tmeahl  | 12/30/2013 | INITIAL RELEASE  |
|--|-------|---|------------|--|
| Revision                                     | ECN # | By  | Date       | Description of Change  |
| Current Revision Information                 |       |   |            |  |
| DIMENSIONS ARE IN INCHES<br>1 inch = 25.4 mm |       | TOLERANCES, UNLESS NOTED<br>X.XX ±0.01 FRACT ±1/16<br>X.XXX ±0.005 ANGLE ±0.05° |            | SURFACE FINISH 250 MICROINCH.<br>BREAK ALL SHARP EDGES 0.015.<br>CONCENTRICITY 0.01 TIR. |
| SPECIFICATIONS UNLESS OTHERWISE NOTED        |       |   |            |  |

**PRIME**  
Equipment Group, Inc.

This document may contain trade secrets and confidential information that is the sole property of Prime Equipment Group, Inc. (Prime). Prime reserves all patent, copyright, trademark and other intellectual property rights in information contained in this document. Recipients of this document are NOT authorized to use, reproduce, copy, disclose or transmit, in whole or in part, the information contained herein without the prior written consent of Prime. All rights reserved. Copyright 2007 Prime Equipment Group, Inc.

Este documento pode conter segredos comerciais e informações confidenciais que é propriedade exclusiva da Prime Equipment Group, Inc. (Prime). A Prime reserva-se todas as patentes, direitos autorais, marcas e/ou outros direitos de propriedade intelectual nas informações contidas neste documento. Os destinatários deste documento NÃO são autorizados a utilizar, reproduzir, copiar, divulgar ou transmitir, no todo ou em parte, as informações aqui contidas sem o prévio consentimento por escrito da Prime. Todos os direitos reservados. Copyright 2007 Prime Equipment Group, Inc.

|             |                 |                   |
|-------------|-----------------|-------------------|
| Material:   | SEE BOM/DETAILS | CUTTER, BACK SKIN |
| Finish:     | SEE BOM/DETAILS |                   |
| Heat Treat: | SEE BOM/DETAILS | Size Part Number  |
| Drawn By:   | tmeahl          | <b>B</b> 70025600 |
| Created:    | 12/13/2013      | Rev. <b>C</b>     |
| Class: -    |                 | SHEET 1 OF 1      |