

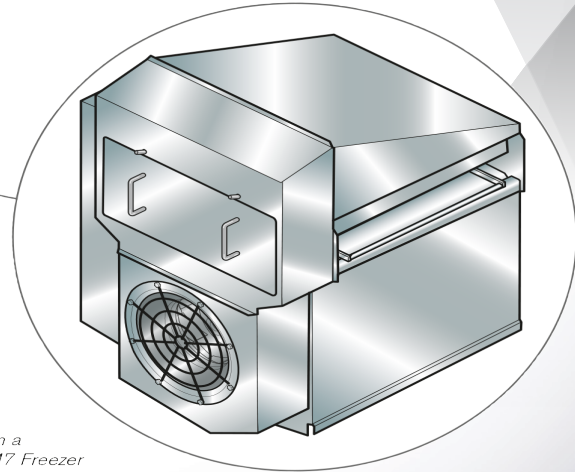

# EQUIPMENT UPGRADE KIT

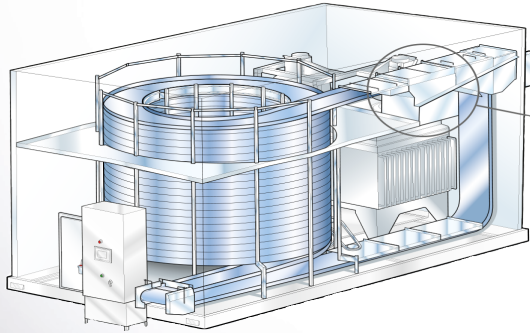

*Example of an Air Balance Tunnel in a  
Frigoscandia GYRoCOMPACT® M7 Freezer*

## Automatic Air Balance Kit

**Improve your air balance automatically to optimize your production**

An upgrade kit can give you more throughput, greater operating safety and better hygiene on your existing equipment - with quality results.

Have you experienced a problem with the air balance in your Frigoscandia freezer or do you find it difficult to adjust the air balance manually? Cold air leaking out of the freezer always pulls in an equal amount of warm and moist air. Air leakage is also a loss of energy.

The intake and exhaust air must balance to meet the system performance requirements and optimize the freezer airflow. The solution is our Automatic Air Balance kit.

## Correct air balance prolongs production running hours

To give you the optimum air balance, JBT has developed a solution that facilitates the time-consuming work with getting the perfect air balance for different products. By automatically controlling the speed of the air balance tunnel fan you will achieve a good air balance independent of other production parameters.

To give you the best product quality, it is essential that food products are frozen quickly under controlled conditions and that all possible measures are put in place to ensure this. The air balance is one of the crucial elements that decides how long you can run your Frigoscandia GYRoCOMPACT® spiral freezer without defrosting.

## How does it work?

By using different measuring points, the freezer's control system either increases or decreases the fan speed in the air balance tunnel to obstruct unwanted air leakage in or out of the freezer.

Requirements:

- Frigoscandia GYRoCOMPACT® spiral freezer with downflow
- S7 PLC system with the MP270 Human Machine Interface (HMI) model or newer. Available as retrofit if needed
- Fan-driven air balance tunnel located above mezzanine floor. Available as retrofit if needed

## What are the benefits?

- Contributes to prolonged production running hours
- Reduces power consumption
- Saves operator's time - no manual adjustments
- Improves product quality

## What's included?

- Modification of the freezer outfeed
- All required hardware
- Upgrade of JBT's PLC and HMI software

## What does it cost?

The cost to implement the Automatic Air Balance kit can vary depending on your equipment, its configuration and your throughput requirements. Please contact your JBT representative or [customersupport@jbt.com](mailto:customersupport@jbt.com) for an exact quotation as well as a calculation of your potential payback time.

As always, we stand behind what we sell. One call gets it all.

## Automatic Air Balance Kit by JBT – Your Solutions Provider

**FRIGOSCANDIA**

**STEIN**

**DSI**



### United Kingdom

John Bean Technologies Ltd  
Heather Park  
Kirkton South Road, Livingston  
West Lothian EH54 7 BT  
Scotland, UK  
Phone +44 1506 857112  
[info-europe@jbt.com](mailto:info-europe@jbt.com)

### Poland

John Bean Technologies Sp.  
z o.o.  
Ul. Przy Bazantarni 11  
02-793 Warszawa  
Poland  
Phone +38 22 894 9025  
[info-poland@jbt.com](mailto:info-poland@jbt.com)

### France

John Bean Technologies SA  
Taverparc - Bâtiment 2.1  
62 Boulevard Henri Navier  
95150 Taverny  
France  
Phone +33 1 84 28 02 00  
[info-europe@jbt.com](mailto:info-europe@jbt.com)

### Spain

John Bean Technologies Spain  
S.L.  
Carretera A2, Km. 34,400  
28805 Alcalá de Henares  
Madrid, Spain  
Phone +34 913 046 698  
[foodtech.spain@jbt.com](mailto:foodtech.spain@jbt.com)

### Russia

John Bean Technologies LLC  
ul. Petrovka 27  
Entrance 2  
RU-107031 Moscow  
Russia  
Phone: +7 495 221 87 12  
[info-europe@jbt.com](mailto:info-europe@jbt.com)

### Sweden

John Bean Technologies AB  
Rusthällsgatan 21, Box 913  
SE-251 09 Helsingborg  
Phone +46 42 490 4000  
Fax +1 419 626 9560  
[info-europe@jbt.com](mailto:info-europe@jbt.com)

### Germany

John Bean Technologies GmbH  
Siemensstrasse 6  
40885 Ratingen  
(Lintorf) Germany  
Phone+49 2102 9341 0  
[info-europe@jbt.com](mailto:info-europe@jbt.com)

### Italy

John Bean Technologies SpA  
Via Mantova 63/A  
43100 Parma  
Italy  
Phone +39 0521 908411  
[sales.parma@jbt.com](mailto:sales.parma@jbt.com)



We're with you, right down the line.™

[jbtfoodtech.com](http://jbtfoodtech.com)