



AGV

Conveyor Deck
Automatic Guided Vehicle



Smooth transfers, integrated flexibility

Our conveyor deck AGVs improve productivity and easily work with conveying equipment.

Capable of handling an array of different load types, our conveyor deck automated guided vehicles (AGVs) smoothly integrate with conveyors. These AGVs can handle anything from pallets, to slipsheets, to racks, and everything in-between. With a variable speed drive operating the rollers, these vehicles synchronize with conveyors in order to fluidly and accurately pass loads back and forth. They can load and unload from either side of the AGV. Even within the most dynamic environments, our conveyor deck AGVs provide a flexible solution to help you achieve improved productivity.

Features & Benefits

Works in a variety of industries

Loads or unloads from the left and the right

Capacity up to 8,000lbs (3,600kg)

Flexible solution for changing demands

Handles a variety of different load types

Interfaces with other automated and manual equipment

360° obstacle detection

Handles raw materials, WIP, and finished goods

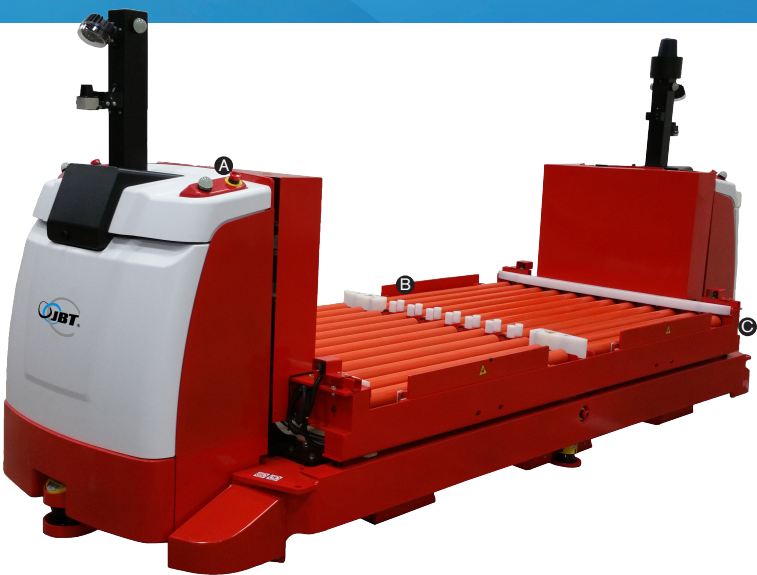

Area of Application

Because of the high degree of flexibility onboard our conveyor deck AGVs, facilities with a diverse load mix and several pick and drop points often benefit the most from these vehicles. Transferring loads back and forth between conveyors is their strong suit. Our conveyor deck AGVs also support different conveyor types, including chain and roller. We can also equip them with a combination conveyor and lift.



Red e-stop push buttons allow for immediate stops in case of emergencies.

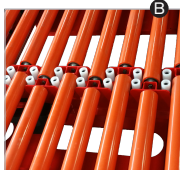

Modular conveyor deck options make the AGV compatible with your specific needs.

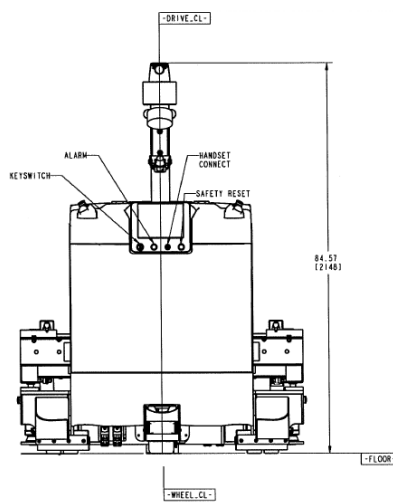
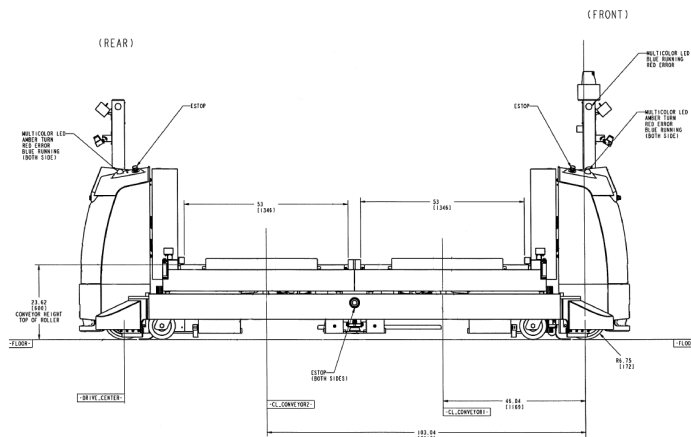

TECHNICAL SPECIFICATIONS

DRIVE	Electric drive
OPERATING POWER	48VDC, Battery-powered
BRAKES	Electromechanical
VEHICLE WEIGHT	10,400lbs (4,725kg) with battery
TRAVEL	Bi-directional; 2.0m/s (393ft/min)
CONTROL	Laser-guidance (automatic); pendant controller (manual)
CARRYING CAPACITY	8,000lb (3,600kg)

North America

John Bean Technologies Corp.
400 Highpoint Drive
Chalfont, PA 18914
USA
Phone +1 215 822 4600
Fax +1 215 822
sgv.sales@jbt.com

Latin America

John Bean Technologies Corp.
Av. Eng. Camilo Dinucci 4605
Il Distrito Industrial - 14808-900
Araraquara, Brasil
+55 16 3301 2000
latinamerica.info@jbt.com

Europe

John Bean Technologies Ltd.
Unit IV Winchester Avenue
Blaby Industrial Park
Blaby Leicester, UK LE8 4GZ
Phone +44 116 264 2250
Fax +44 116 264 2279
uksgvsales@jbt.com

