



Counterbalance 2500 (AGV)



Flexible transport, maneuverable power

Our counterbalance AGVs move your materials and transform your business.

Vehicle Features

- Small footprint for greater maneuverability
- Flexible service to racking, conveyors, stands, etc.
- Capable of block stacking various load types
- Navigates tight spaces
- Interfaces with racks, conveyors, AS/RS, and other plant equipment
- Compatible with various fork attachments, such as double forks

Ideal for handling pallets, racks, and rolls, our counterbalance automatic guided vehicles (AGVs) excel in floor-to-floor transfers. However, they are not limited to floor operations and can interface with plant equipment, like racks, conveyors, and AS/RS. Our counterbalance vehicles also provide excellent versatility. The lift mast, mounted at the very end of the vehicle, keeps the AGV clear of loads and minimizes vehicle width. This allows the AGV to handle multiple load types without complications.



Vehicle Features



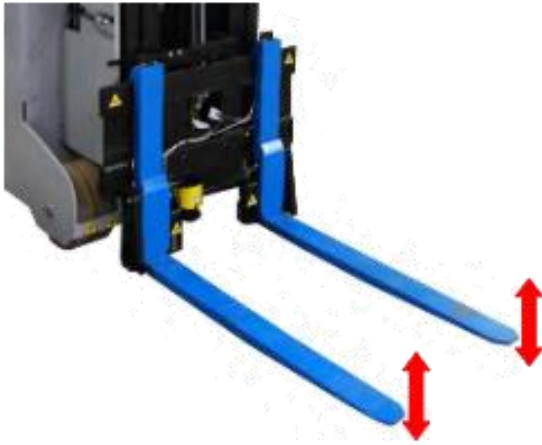

Fork Tilt

- Hydraulic
- +4/-1 degrees
- Trailer Loading
- Pushback Racking

Multi Fork

- Four Fixed Forks
- Single Double-2 Forks become 4
- Double Load Stacking

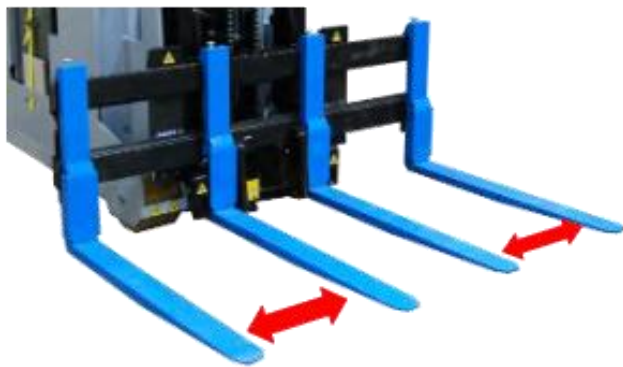

Vehicle Features

- Small footprint for greater maneuverability
- Flexible to service racking, conveyors, stands, block stacking, etc.



Hydraulic Lift

- Single or Multistage
- Slack Chain Protection
- Auto Height Calibration
- Multiple Attachments

Side Shift

- Hydraulic
- +/- 203mm Shift
- Auto calibration
- Trailer Loading



Vehicle Specifications

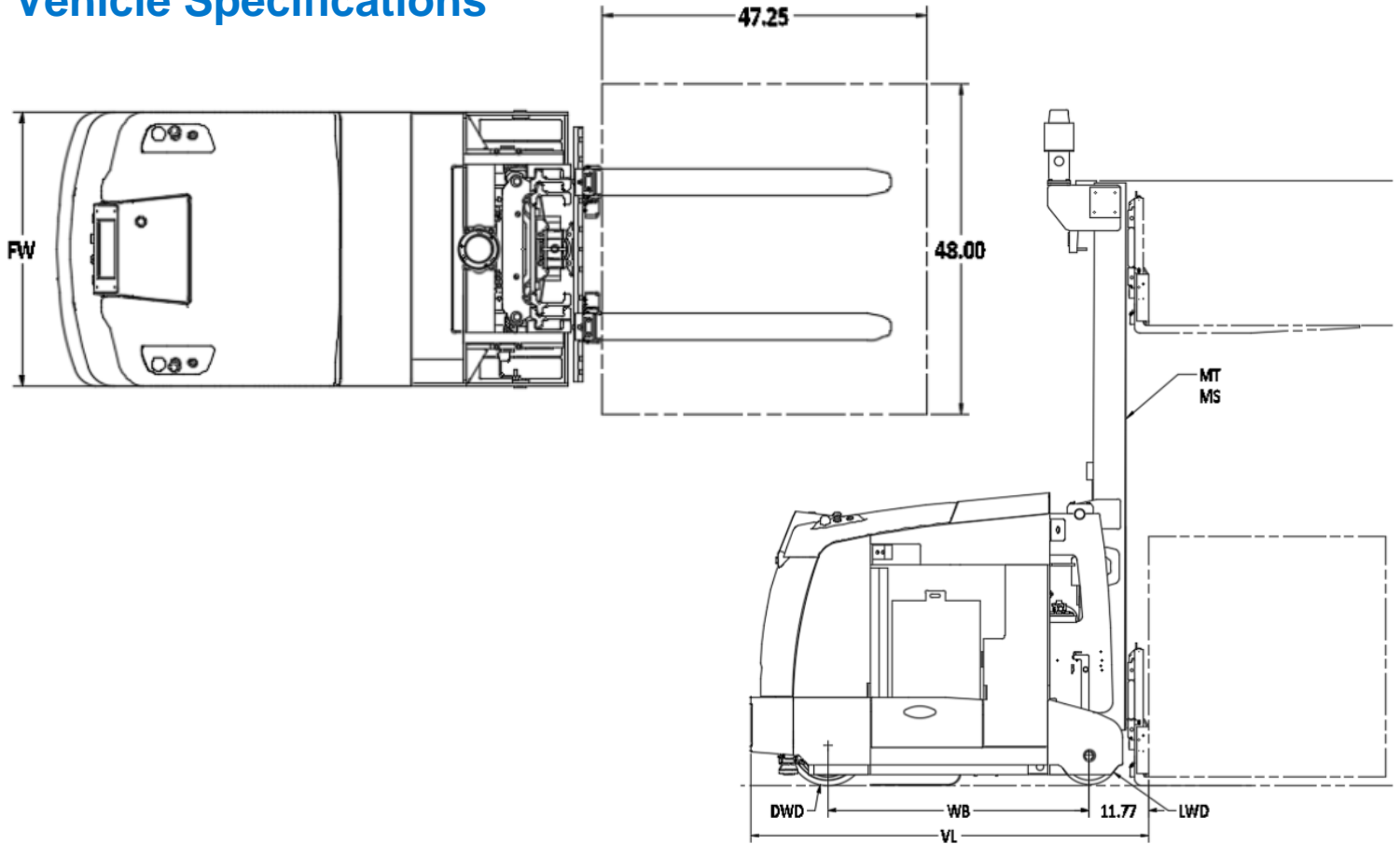

TECHNICAL SPECIFICATIONS

DRIVE	Electric Drive
OPERATING POWER	48VDC, Battery-powered
BRAKES	Electromechanical
LIFT POWER	Hydraulic
VEHICLE WEIGHT	920kg with battery
TRAVEL	Bi-directional; 2.0m/s
CONTROL	Laser-guidance/natural (automatic); pendant controller (manual)
LIFT CAPACITY	750kg
ELEVATED HEIGHT	6 m
DRIVE WHEEL	35cm ; 30cm Diameter x 10cm

SAFETY FEATURES (STANDARD) Flashing Lights, Emergency Stop Buttons, Obstacle Sensing Bumpers, Horn