



AGV

Tugger Automatic
Guided Vehicle



Small footprint, big power

Our tugger AGVs maximize productivity while minimizing costs.

Perfect for pulling wheeled carts, our tugger, or towing, automatic guided vehicles (AGVs) haul more loads per trip than other AGV types. As a result, they maximize productivity. Tugger AGVs can interface with other automated and manual equipment, including forklift-style AGVs, and typically operate in a loop. A simple solution to repetitive material movement, tugger AGVs safely transfer goods from station to station. Whether you're moving raw materials, work-in-process (WIP), or finished goods, tugger AGVs can handle the load.

Features & Benefits

Works in a variety of industries

Several hitch options: ball, pin, or automatic

Capacity up to 50,000lbs (22,600kg)

3 drive wheels for optimal maneuverability and flexibility

Tows a variety of different load types

360° obstacle detection

Interfaces with other automated and manual equipment

Handles raw materials, WIP, and finished goods



Area of Application

Built to last, our tuggy AGVs can withstand even the toughest environments and have been a common fixture in automotive plants for years. Their versatility, driven by their ability to handle a variety of loads, makes them a popular option in high-demand facilities. In tuggy AGVs, simplicity meets durability.

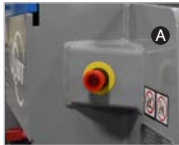
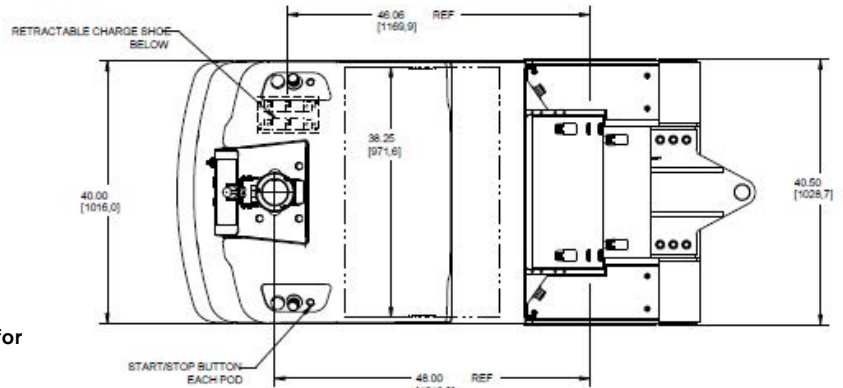

Red e-stop push buttons allow for immediate stops in case of emergencies.



Optional automatic hitch reduces transition times between the AGV and cart to increase overall system productivity.



Driven rear wheels increase carrying capacity and power up inclines.

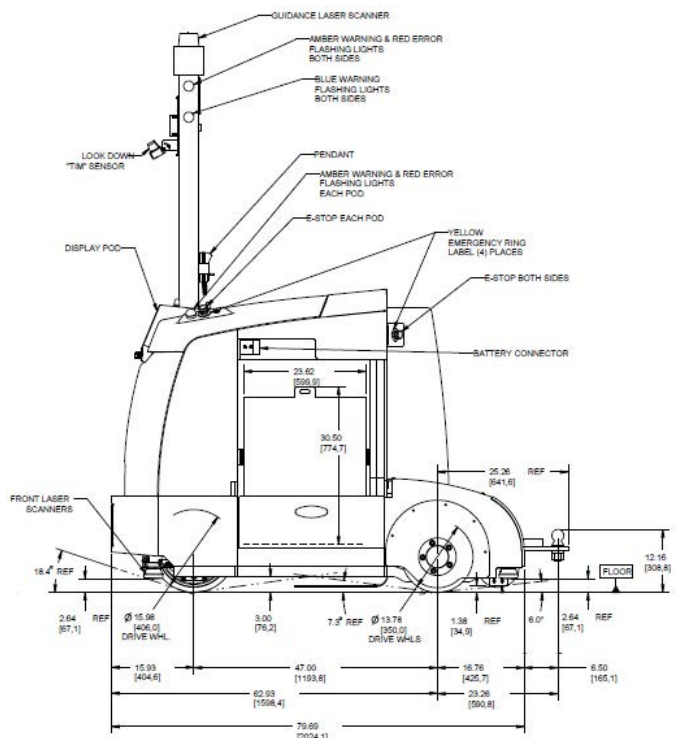

TECHNICAL SPECIFICATIONS

DRIVE	Electric drive
OPERATING POWER	48VDC, Battery-powered
BRAKES	Electromechanical
VEHICLE WEIGHT	9,300lbs (4,200kg) with battery; 6,000lbs (2,700kg) without
TRAVEL	Bi-directional; 1.78m/s (350ft/min)
CONTROL	Laser-guidance (automatic); pendant controller (manual)
CARRYING CAPACITY	50,000lbs (22,600kg)

North America
 John Bean Technologies Corp.
 400 Highpoint Drive
 Chalfont, PA 18914
 USA
 Phone +1 215 822 4600
 Fax +1 215 822
 sgvsales@jbt.com

Europe
 John Bean Technologies Ltd.
 Unit IV Winchester Avenue
 Blaby Industrial Park
 Blaby Leicester, UK LE8 4GZ
 Phone +44 116 264 2250
 Fax +44 116 264 2279
 uksgvsales@jbt.com

Latin America
 John Bean Technologies Corp.
 Av. Eng. Camilo Dinucci 4605
 Il Distrito Industrial - 14808-900
 Araraquara, Brasil
 +55 16 3301 2000
 latinamerica.info@jbt.com

